

POWERTEC
INDUSTRIAL MOTORS
Subsidiary of Peerless-Winsmith, Inc.

Model 4000

BRUSHLESS D.C. MOTOR CONTROL

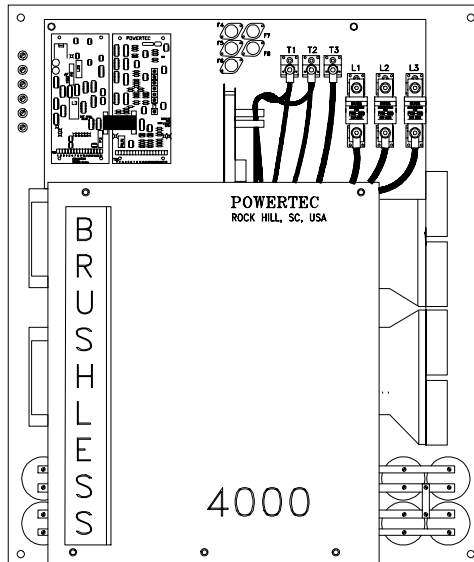

INSTALLATION AND OPERATION INSTRUCTION MANUAL

APRIL 12, 1993

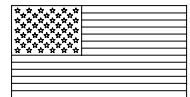

MADE IN USA

Mailing Address: P.O. Box 2650 * Rock Hill, South Carolina USA 29732 * PHONE: 803-328-1888
Shipping Address: 2606 Eden Terrace * Rock Hill, South Carolina USA 29730 * FAX: 803-328-1870
www.powertecmotors.com

MODEL 4000 INSTRUCTION MANUAL

TABLE OF CONTENTS

LIST OF ILLUSTRATIONS	ii
SUMMARY OF WARRANTY	iii
WARNING NOTICE	iii
POWERTEC SCHOOLS	iii
1.0 INTRODUCTION	
1.1 BRUSHLESS MOTOR TECHNOLOGY	1
1.2 NON-REGEN VERSUS REGEN OPERATION	2
1.3 A BRUSHLESS DC PRIMER	3
1.4 BRUSHLESS MOTOR BENEFITS	7
1.5 HOW TO USE THIS MANUAL	7
2.0 APPLICATION DATA	
2.1 ELECTRICAL RATINGS	9
2.2 DIMENSIONS	9
2.3 ENVIRONMENTAL	9
2.4 PERFORMANCE	10
2.5 CUSTOMER ADJUSTMENTS	10
2.6 INDICATORS	10
2.7 TERMINAL DESCRIPTIONS	10
3.0 PHYSICAL INSTALLATION	
3.1 RECEIVING.....	11
3.2 BEFORE INSTALLATION	11
3.3 INSTALLATION.....	12
3.4 THERMAL CONSIDERATIONS	12
4.0 ELECTRICAL INSTALLATION	
4.1 GENERAL REQUIREMENTS.....	13
4.2 POWER SUPPLY	13
4.3 CONNECTING THE MOTOR	15
4.3.1 MOTOR LEADS.....	15
4.3.2 MOTOR GROUND	15
4.3.3 OUTPUT CONTACTOR	16
4.3.4 MOTOR FEEDBACK CABLE.....	16
4.4 CONTROL CONNECTIONS	16
4.5 REFERENCE OPTIONS.....	18
4.5.1 ANALOG REFERENCE	18
4.5.2 DIGITAL REFERENCE	19
4.6 AUXILIARY CIRCUITS	20
4.7 P.L.C. INTERFACE	22
5.0 OPERATION	
5.1 ANALOG INPUT OPERATION.....	23
5.1.1 SPEED REFERENCE	23
5.1.2 MINIMUM SPEED	23
5.1.3 ACCEL AND DECEL	24
5.1.4 MAXIMUM SPEED	24
5.1.5 RAMP STOP	25
5.1.6 JOG FUNCTION	25
5.1.7 BI-DIRECTIONAL JOG	25

TABLE OF CONTENTS (continued)

5.0	OPERATION (CONTINUED)	
5.2	DIGITAL MODE	26
5.3	CURRENT LIMIT	26
5.4	GAIN AND STABILITY	27
6.0	THEORY AND TROUBLESHOOTING	
6.1	INPUT POWER SECTION	29
6.2	CHARGING SECTION	29
6.3	CURRENT SENSOR BOARD	30
6.4	POWER OUTPUT SECTION	31
6.5	CURRENT CONTROLLER BOARD	33
6.6	SPEED CONTROLLER	34
6.7	TROUBLESHOOTING	35
7.0	SPARE PARTS	39

LIST OF ILLUSTRATIONS

1.	Comparison of speed regulation.....	1	19.	Auxiliary RUN relay.....	20
2.	Stopping methods compared.....	2	20.	FAULT relay.....	21
3.	Input power section.....	3	21.	ENABLE relay.....	21
4.	Power output bridge.....	3	22.	ZERO SPEED relay.....	21
5.	Single wye motor connections.....	4	23.	Chatter elimination.....	22
6.	Simplified drawing of motor.....	4	24.	SINKING connection to PLC.....	22
7.	Current flow at turn-on.....	5	25.	SOURCING connection to PLC.....	22
8.	Motor rotation result.....	5	26.	Connecting FAULT output to PLC.....	22
9.	The encoder assembly.....	6	27.	Connections for minimum speed.....	23
10.	Parts layout of the Model 4000.....	8	28.	Simplified drawing of power circuits....	28
11.	4000 Chassis dimensions.....	11	29.	Parts layout of Current Sensor board.	30
12.	4000 NEMA 1 dimensions.....	12	30.	Layout of Base Driver board.....	31
13.	Standard connections.....	14	31.	Block diagram of the 4000.....	32
14.	Input power connections.....	15	32.	Current Controller board layout.....	33
15.	Output contactor.....	16	33.	Speed Controller board layout.....	34
16.	Digital mode inputs.....	19	34.	Typical configurations of semiconductors	
17.	Frequency output.....	20	37.		
18.	Follower connection.....	20	35.	Connections to DIGIMAX IV.....	38

SUMMARY OF WARRANTY AND DISCLAIMER

POWERTEC Industrial Corporation guarantees the **Model 4000** Brushless DC motor controls which it manufactures to be free from defects in materials and workmanship for a period of one year from the date of original shipment, or, if purchased from an authorized distributor or original equipment manufacturer, for no more than 18 months from the date of original shipment from the factory. Upon written notification to the factory of a defect in materials or workmanship in a warranted unit, **POWERTEC** will, at its sole option, repair or replace **at the factory** such defective parts as it deems necessary to restore the unit to service. Shipping charges to and from the factory, taxes, and duties are the responsibility of the user.

There is no other warranty, expressed or implied, including fitness of purpose for the application intended. This warranty does not cover accidental or intentional damage, accidental or intentional abuse, effects from defective or incorrect installation, effects on other equipment, or any other situation over which **POWERTEC** has no control.

This warranty does not encompass any other claims, including, but not limited to, special, incidental, or consequential damages.

This manual has been written as a guide to the use of **POWERTEC** products. It represents the best efforts to compile the information contained herein. Such mistakes as may appear in no way affect the above stated warranty. If mistakes of fact are found in this manual, please notify your distributor or **POWERTEC** at once.

WARNING!!

**THE POWERTEC MODEL 4000 OPERATES NORMALLY AT HIGH VOLTAGE
AND POWER LEVELS WHICH CAN CAUSE INJURY OR DEATH!
ONLY PERSONNEL QUALIFIED IN THE MAINTENANCE OF HIGH VOLTAGE, HIGH POWER
EQUIPMENT SHOULD WORK ON THESE CONTROLS.
BEFORE WORKING ON THIS EQUIPMENT, READ THIS ENTIRE MANUAL.**

POWERTEC SCHOOLS

POWERTEC Industrial Corporation conducts periodic service schools to promote the training and understanding of its customers, representatives, and distributors. These schools are held at the factory in Rock Hill, South Carolina. Schools at other locations may be arranged with the service department.

The two-day school at **POWERTEC** emphasizes basic concepts, block diagram and schematic study, systems application, and there is a hands on training period. Attendees also tour **POWERTEC**'s modern new facility and meet the people who serve their needs.

There is a nominal charge to cover the cost of materials. Also included are two lunches, a dinner, and snacks. The person attending is responsible for lodging, other meals, and transportation to and from Rock Hill, SC (20 miles south of Charlotte, North Carolina).

For further information, PHONE: 803-328-1888
or FAX: 803-328-1870

1.0 INTRODUCTION

1.1 BRUSHLESS DC MOTOR TECHNOLOGY

Traditional AC induction motors must “slip” (fall behind their natural “synchronous” speed) in order to develop torque. The synchronous speed is determined by the frequency of the power at the motor terminals. At 60 Hertz (the power line frequency in the USA) a four pole AC induction motor will have a synchronous speed of 1800 RPM. With a full load on the motor, however, the motor will only be turning at 1740 RPM (curve A in Figure 1), due to the necessity of slip to develop torque.

An AC induction motor running near synchronous speed does not develop any torque. The amount of slip varies with the amount of torque required from the motor. Since slip is a percentage of the operating speed, and the amount of slip varies with the load, it is difficult to predict the speed at which an AC induction motor will run under any given set of operating conditions, whether it is operated across-the-line or on the output of a variable frequency control. It is very difficult to main-

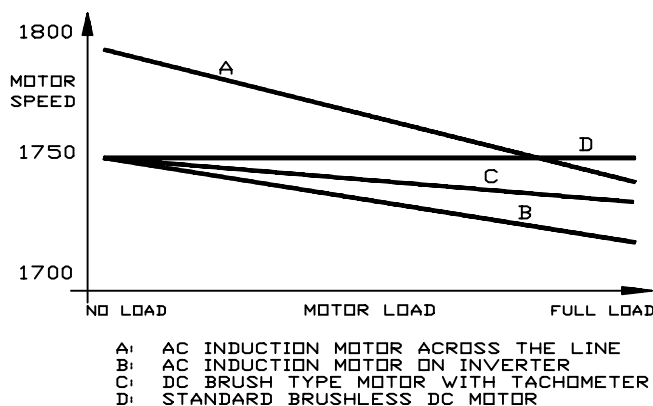

Figure 1: Comparison of speed regulation of typical industrial motors from no load to full load.

tain an exact speed when operating under varying load conditions. Extraordinary means must be used to employ AC motors in speed sensitive applications.

Inverters do not help much with AC induction motors, but they do improve speed regulation a little by increasing the applied frequency as the load increases (curve B in figure 1).

Traditional brush-type DC motors are operated using mostly solid-state AC to DC power converters which have inherent limitations on their ability to provide power when and as needed. At best they can supply power only 360 times per second with three phase input power, or 120 times per second with single phase input power. Worse, the brush-type DC motor is a self commutating device which uses the applied power inefficiently, and loses some of the power on the way to the

place where it really counts.

The speed of the DC motor is determined by the voltage applied at the brushes where they come in contact with the commutator, which is a few windings, and many voltage drops (known as IR losses), away from the output terminals of the motor control, where the motor's CEMF (armature voltage) is often used to regulate speed. Since the voltage differences between the brushes and the motor control output vary with load, speed varies with load. Extraordinary means must be used to employ DC brush-type motors and solid-state SCR controls in speed sensitive applications.

Even when a DC tachometer is used with a brush-type DC motor to regulate speed (curve C in Figure 1), the tachometer only reads an AVERAGE speed, and the resolution between speeds limits the response.

The Brushless DC motor and control system overcomes these problems to provide smooth and efficient power and speed control. Its speed regulation is not measured in percentage of RPM, as is the case with other types of motor and control systems, but in physical shaft position within a single revolution. With a brush-type DC motor and solid state SCR control, speed regulation of +/-0.5% might be obtained with a *very expensive* tachometer. This means that a motor set for 1750 RPM may be operating anywhere between 1741 RPM and 1759 RPM and still be within specifications. A brushless DC motor set for 1750 RPM must run at 1750 RPM, period. The only alternative is to be in current limit. Short of current limit, the brushless D.C. motor may not be more than 240 degrees behind its no load shaft position with the standard control set at its *minimum* gain. The Brushless DC motor control does not look at its speed, it looks at *where the motor shaft is in relation to where it should be*.

The Brushless DC motor control also can supply power when and as needed at a rate which more than five times the solid-state SCR control's line limited rate.

All of this comes in a compact package which will exceed the performance of across the line operated AC motors, AC adjustable frequency operated motors, or the conventional DC brush-type motors.

POWERTEC's Brushless DC motors have the high reliability and low maintenance requirements which have always been associated with AC induction motors. Brushless D.C. motors have speed and torque control which are superior to the traditional brush-type DC motor, plus a very high level of efficiency.

The Brushless DC motor and control give your industrial applications outstanding performance, long life, and very efficient service in the the most demanding industrial conditions.

1.2 NON-REGEN VS. REGEN OPERATION

The **POWERTEC** Model 4000 is a *non-regenerative* Brushless DC motor control. They will not accept any energy coming back from the motor due to overhauling loads and high inertias during deceleration. The Model 4000RG from **POWERTEC** is *regenerative*. This section explains the difference.

When a motor is operating with a load in such a way that it is drawing current from the power supply, it is said to be operating in the **MOTORING** mode. This is the most common mode of motor operation, used to power industrial processes in almost all applications. The motor is converting the electrical energy from the plant power supply into mechanical energy (work) at the motor's output shaft.

When any electric motor rotates, it produces a potential at its main terminals. This potential is due to the movement of the rotor or armature windings through a magnetic field, as in the case of the brush type D.C. motor or the induction A.C. motor. This potential is called Counter-Electro-Motive-Force (CEMF, for short). CEMF is produced by the motor even when it is drawing power from the supply, and the CEMF tends to oppose the flow of current from the supply to the motor. In the case of the brushless D.C. motor, a field produced by the magnets on the rotor is

moving around the stationary windings of the stator. If the voltage produced by the rotation of the motor shaft (due to the CEMF) exceeds the supply voltage, the motor can not draw current from the supply as long as this situation exists. Usually this condition is produced when motor speed is greater than the speed commanded by the reference, perhaps due to the amount of inertia of the load being greater than the amount of inertia which can be slowed by the motor in the time allotted, or when the load is being moved by another force faster than the motor wants to turn.

A load in motion will come to a free-wheeling stop by "coasting" in an amount of time determined by the speed, inertia, and friction of the load. The faster a load is moving, the longer it requires to stop. Larger inertias (generally speaking, more mass) take longer to stop, but a higher friction load slows it down faster. A moving load stops in a coasting situation by dissipating the energy of motion as frictional heat, which acts as a brake. If inertia is high and friction is low, the load will take a longer time to stop. Mechanical brakes may be used to increase the amount of friction.

Non-regenerative motor controls do not have the ability to slow down a load in a time which is less than the motor would normally slow down by itself, or come to a stop, by coasting. It cannot act as a brake, so it shuts off and waits for speed to fall below that commanded by the reference at the time (if the control is active). Braking force may be supplied by the motor by dissipating the energy into passive resistors connected after the control is shut off (dynamic braking).

Regenerative motor controls are capable of supplying braking force while the motor control is active. A motor rotating at a speed which faster than its control is commanding becomes a generator. The amount of power generated is related to the speed, the total inertia, and the friction of the load and motor combination.

It is also proportional to the dissipative and/or storage load presented by the controller, which must be adequate. The regenerative control will accept current from the motor, and will dissipate the energy received, as long as the load it presents is sufficient to dissipate the energy.

When energy is being generated by the motor, and being accepted by the controller, then the motor is said to be **REGENERATING**. A motor in the regenerating mode develops torque in the opposite direction of its rotation, and is not drawing power from the supply, as it is in the motoring mode.

Regenerative power capability gives the motor and control the ability to change from higher speeds to lower speeds (including zero speed, and also including the reversal of motor direction) much more quickly than with non-regenerative types of controls, resulting in more rapid stops and quick reversals of loads which would otherwise be a lot more sluggish in these actions.

COMPARISON OF STOPPING METHODS

COAST TO STOP - FRICTIONAL BRAKING ONLY
 DYNAMIC BRAKING - PASSIVE BRAKING RESISTANCE
 REGENERATE TO STOP - ACTIVE BRAKING POWER

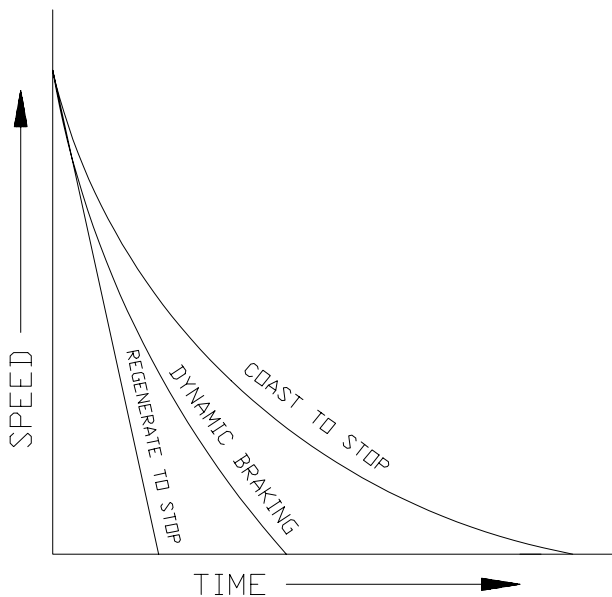

Figure 2: Stopping methods for motors compared.

1.3 A BRUSHLESS D.C. PRIMER

Three phase AC plant power is converted to DC by the input side of a Brushless DC motor control to charge up a "bank" of storage capacitors (called the "buss"), whose function is to store energy and supply DC power to the power transistors in the output bridge as power is required by the motor. The size of the buss (the number of capacitors) varies with the size of the motor.

This rectification is accomplished by six diodes, which

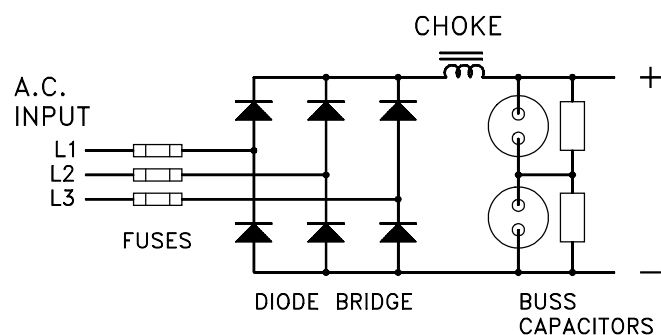

Figure 3: Simplified drawing of input power section of a Brushless DC motor control.

may be in a single package or in several modules. The diodes are protected by the input fuses, which are chosen for their speed and interrupting capacity. An input choke in the DC leg of the diode bridge protects against line transients and limits the rate at which input current may increase or decrease.

This input section is self regulating. The highest voltage level possible on the capacitors is 1.4 times the line-to-line voltage (the peak voltage). Initially, before the motor is turned on, the capacitors will charge up to this peak voltage. When the motor is started, it uses power from the buss to perform the work required. The effect of this is to partially discharge the capacitors, lowering the buss voltage. With three phase input power, there are six periods in each cycle of AC when the line-to-line voltage is greater than the capacitor voltage. The capacitors will only draw current from the power lines when the capacitor voltage is lower than the instantaneous line-to-line voltage, and then it will only draw enough power to replenish the energy used by the motor since the last time the line-to-line voltage was greater than the capacitor voltage.

Torque in a motor is a function of current. Power is a function of speed AND torque. Even though the current required by the motor to develop the torque may be large, the actual power used is small at low speeds. Because the energy drawn from the capacitors is the **actual power used by the motor**, the energy drawn from the input power lines is the actual power supplied to the motor. The Brushless DC motor control is capable of running at very low speeds at very high torques while drawing very little current from the AC line. The result of this is that the RMS current at the

input of the Brushless DC motor control is directly proportional to the output power of the motor, rather than being proportional to the motor's load.

A Brushless DC motor is wound like an AC induction motor, but it uses permanent magnets on the rotor instead of shorted rotor bars. There are three power carrying wires going to the motor. Each of these wires has to be, at synchronized times, connected to either side of the DC buss. This is accomplished with a six transistor power output bridge configuration (figure 4).

Applying power to the motor requires turning on one transistor connected to the positive side of the buss and one transistor connected to the negative side of the buss, but never the two transistors in the same leg of the output. When two transistors are turned on, the entire buss voltage is applied to the windings of the motor through the two wires connected to those transistors and current will flow (if the CEMF of the motor is not greater than the buss) until the transistors are turned off. Due to the inductive nature of the motor windings, the current will not cease immediately when the transistors are turned off. It will decay quickly, but voltages in the bridge would rise dangerously if the snubber network were not present to prevent this from happening.

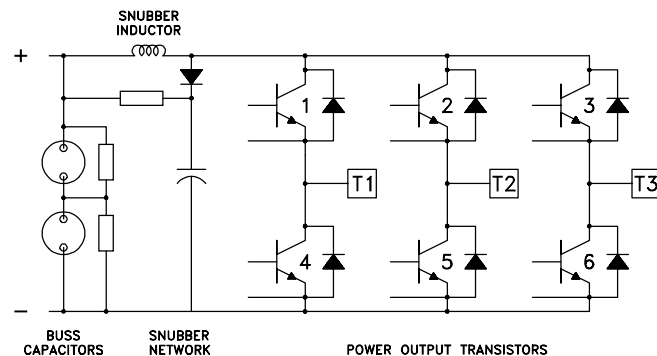

Figure 4: The power output bridge consists of six power transistors and associated snubber components.

If two transistors were turned on and left on for any length of time, the current would build to very high levels too quickly, so the transistors are turned on for only brief intervals at a time. If the motor is lightly loaded, it will not take a lot of current (torque) to get it going. If the motor is heavily loaded, each turn-on interval will cause the current to build up until there is sufficient torque to turn the load. Once the motor has started turning, the current supplied will be, in either case, **just enough** to keep the motor and load turning. If a heavy load is taken off the motor, the current will quickly drop to the new level, and an applied heavy load will be quickly picked up. This accounts for the high efficiency of Brushless DC.

Figure 5 is a schematic representation of the windings of the Brushless DC motor. The connection shown in the drawing is a single-wye. There are three other ways the motor windings can be connected which will change the speed and horsepower (the torque remains constant in any given motor as the connections are changed), but these other connections are not made for different voltages as is the case with the AC induction motor. The standard connection conventions of the AC motor are followed in the assignment of markings on the motor leads, however. For further information on motor connections see the **POWERTEC** motor manual.

Shown in Figure 6 are the major parts of the **POWERTEC** Brushless DC motor in the off state. The stator windings are connected as in figure 5 and the motor is operated from the power bridge shown in figure 4. This drawing is *very simplified*, showing only a two pole motor, for simplicity. Most **POWERTEC** Brushless DC motors are 4 pole or 8 pole motors.

Current is developed in the windings, producing torque by the interaction of magnetic fields, produced by the stator windings (with the power supplied from the control) and the fields of the permanent magnets mounted on the rotor.

The Brushless DC motor control has an "electronic commutator", fed by an integral encoder mounted on the motor. This encoder tells the motor control which transistors should be turned on to obtain the maximum torque from the motor at whatever position the motor shaft happens to be in at that point in time. This establishes a communication between the motor and its control which is not present in AC motors and inverters, and which is not a part of the DC

brush-type motor and its SCR control. The Brushless DC motor control always knows where the motor shaft is in its rotation because the motor encoder is constantly monitoring it.

The control's power output bridge (figure 4) consists of three "legs". Each leg has a power transistor from the positive side of the DC power buss to the output terminal (generally referred to as an "upper" transistor), and another transistor from the output terminal to the negative side of the DC power buss (herein referred to as a "lower" transistor). Each time a transistor turns on, it connects an output terminal to one of the sides of the DC power buss. Each output terminal also has a "free-wheeling" diode connected to each side of the buss to carry currents which the transistors cannot conduct.

Again, at whatever position the rotor happens to be, the encoder

tells the drive which transistors should be turned on to deliver maximum torque from the motor. While this is actually done in an EPROM (an Electrically Programmable Read Only Memory integrated circuit), the simplified representation as a switch shown in figure 6 will suffice for our purpose. Note that the longer arrow on the switch in the diagram governs the switching of the upper transistors, which are numbered 1, 2, and 3. The shorter arrow governs the switching of the lower transistors 4, 5, and 6. The arrangement is such that each of the upper transistors may be operated with either of the lower transistors in the other two output legs, but an upper transistor may never be operated with the lower transistor in the same leg. To do so would produce a short circuit across the DC power buss and blow out the fuses, if not the transistors involved. The driver circuits are also logically interlocked to prevent the accidental turning on of opposing transistors.

The rotor in figure 6 has two sets of magnets on it, a North Pole and a South pole, which will interact with the electro-magnetic fields and poles which are produced by the current in the stator windings (shown in figure 5 schematically and in their relative positions around the rotor in figure 6). Remember that the rotor is free to turn, but the stator windings are stationary.

When the control is turned on in the position shown (Figure 7), transistors 1 and 5 will turn on, allowing current to flow from the positive side of the buss through the number 1 transistor out of the control terminal T1 into the T1 winding of the motor and through T4 to T7 and through T10 to the center of the motor connection. Since the number 5 transistor is on, the current will flow through T11 to T8 to T5 and T2 in the motor to T2 on the motor control through

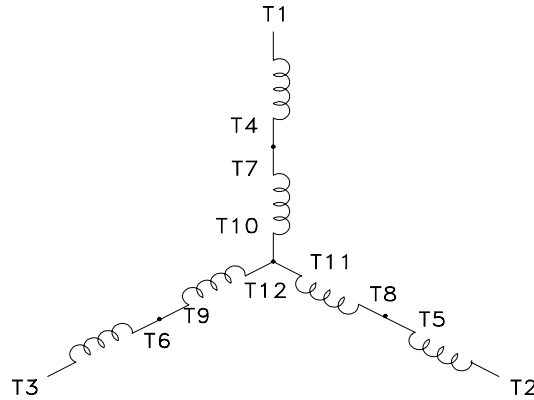

Figure 5: Single-wye connections for a Brushless DC motor.

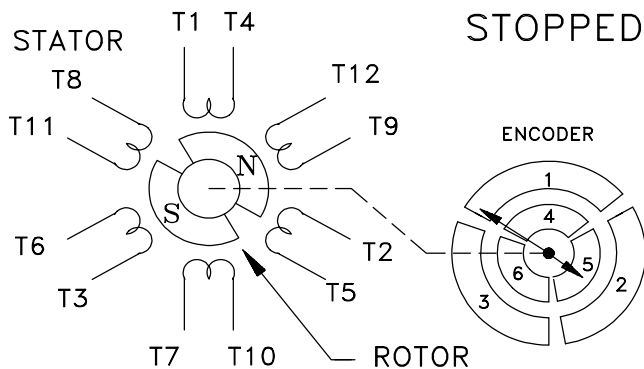

Figure 6: Simplified drawing of the major parts of the Brushless DC motor.

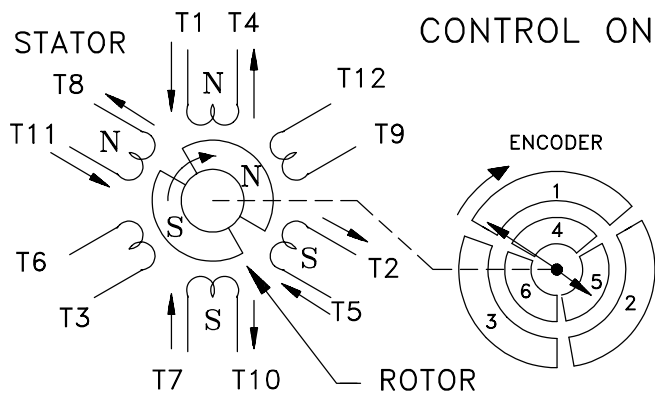

Figure 7: Current flows in the stator of the motor after the control is turned on in the position shown.

the number 5 transistor to the negative side of the buss. The currents will be as indicated in figure 7, setting up magnetic poles in the stator as shown (North poles at T1-T4 and T11-T8, and South poles at T7-T10 and T2-T5). The North poles in the stator attract the South pole of the rotor and repel the North pole of the rotor, and the South poles in the stator attract the North pole of the rotor and repel the South pole. Rotation will occur in the indicated direction as torque is developed in the motor.

Since the load is heavily inductive, this current would build in a nearly linear way if the transistors were on continuously, but the switching of the lower transistors is pulse-width modulated, i.e., switched on and off at a relatively high frequency. The width of each pulse is determined by the torque required to turn the motor, which is under speed and, effectively, position control. The amount of torque required is determined by the load on the motor shaft. The lighter the load, the narrower the pulse width. As the load gets heavier, the pulses will get wider until they reach their maximum width.

With each pulse the current will build up a little until the end of the period of time that the two transistors are on, which will occur when the motor has turned far enough to turn off the 5 transistor. In this example, that will occur when the rotor has turned 60 degrees (in the actual motor, that will occur in 60 electrical degrees, not in 60 physical degrees as in the illustration. There may be as many as 1440 electrical degrees per revolution in a motor). Then the next step will occur as the 5 transistor turns off, and the 6 transistor turns on (figure 8).

Between the pulses and between stages of operation, the inductive current will want to continue to flow (since current cannot be created nor destroyed instantaneously in an inductive circuit) if the energy is not used by the turning of the load, and the continued flow of current is allowed through the free-wheeling diodes which are in inverse parallel connection with each output transistors. In this case the current, which is entering the motor at T1 and exiting at

T2, will be forced to flow through the diodes around transistors 2 and 4. This current will decay rapidly, and it has the effect of slowing the motor down by loading it. It also has the effect of charging up the buss, but unless the motor has a large inertia on its shaft, and is turning at a very high speed, it will have little effect.

After the motor has turned about 60 electrical degrees from the position shown in figure 7, the 5 transistor will turn off and the current in the T11-T8-T5-T2 leg will die out; the 6 transistor will pick up the operation. Then the current flow will be through the T1-T4-T7-T10 leg to the center of the wye, and out through the T12-T9-T6-T3 leg. The stator magnetic poles will have shifted 60 degrees, causing the rotor to continue to move in that direction.

Unlike the DC brush-type DC motor, which can only fire its SCR pairs every 2.6 milliseconds (.0026 second) at best, the brushless DC motor control can operate its transistors during the entire commutation cycle. A 2 kilohertz PWM frequency allows the operation of a transistor every 500 microseconds (.0005 seconds). Frequencies from 2 kilohertz to 20 kilohertz or more are common. There is also no need to wait for the power line conditions to shut off the transistor; it may be cut off at any time. This allows for very tight control of the current and speed of the BLDC motor. Since speed and current (torque) are tightly controlled, power is also. The tight control of the power going to the motor results in very high efficiency.

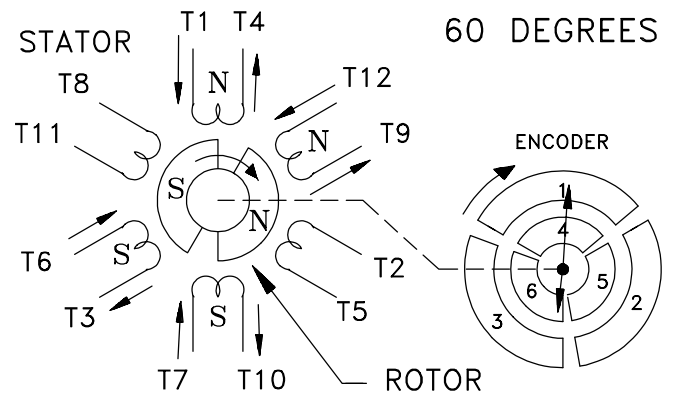

Figure 8: When the motor rotates 60 degrees the encoder switches the output transistors to rotate the field.

While the field moves around the stator, the rotor follows it. Unlike the induction AC motor, in which all windings are continuously excited, the brushless DC stator is a DC excited field, and it moves because the windings are continuously switched in response to the movement of the rotor. The non-excited windings are carrying no current, since the windings in a brushless DC motor are either on or off. They do not go through the slow transitions that the AC motor windings goes through. If winding switching were to stop, the motor would come to a halt.

The switching of windings is controlled by a three channel position encoder mounted on the motor shaft. The hall effect transistors which are mounted on the feedback assembly are turned on and off by magnets in the encoder's "xolox wheel". These magnets are aligned with the magnets on the rotor. The hall effect switches, which are non-contact (electrically isolated) devices, are mounted in positions 60 degrees apart (on a four-pole motor, they are 30 degrees apart on an eight pole motor). It is not possible for the three switches to be all on or all off at the same time. There will always be two on and one off, or one on and two off, at all times.

The speed of **POWERTEC**'s four pole brushless DC motor is regulated by a two channel, 30 pulse (60 pole) digital tachometer on the motor shaft, which indicates both speed and direction of rotation. Eight pole motors (frames 280 and larger, except over 2500 RPM) have 120 magnetic

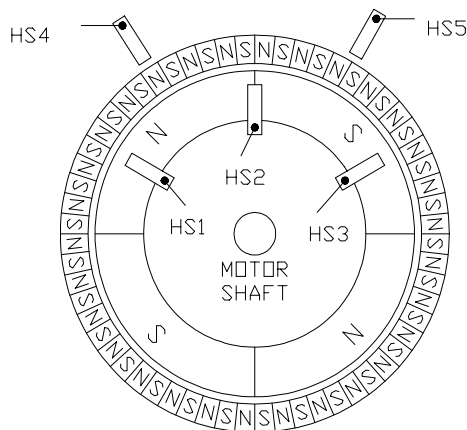

Figure 9: The encoder assembly - four magnets indicate position; outer magnets indicate speed and direction.

poles around the outside of the xolox wheel. These poles alternately turn on and off two hall effect switches which are connected to the control for speed control. There are two speed feedback channels which are offset by 90 electrical degrees, in quadrature.

These 30 pulse per revolution signals from the motor are electronically multiplied by 4 to supply a pulse every 3 degrees of shaft rotation (larger motors use a 60 pulse tachometer, yielding 240 pulses per revolution, a pulse every 1.5 degrees). Reference pulses are compared to pulses coming back from the motor's encoder. If the number of pulses from the motor (the absolute number, not the frequency) do not equal the number of reference pulses applied, a position error count accumulates in an up/down counter on the Speed Controller board. The number of accumulated pulses determines how much current is made

available to the motor. If there are more reference pulses than feedback pulses, the accumulation is positive, and the current to the motor is positive, i.e., motoring current. This positive current will try to accelerate the motor to eliminate the pulse count. If there are more feedback pulses than there are reference pulses, the count is negative, and the motor current will be shut off (the motor will coast along) until the accumulated count becomes positive again.

A motor running at no load will accumulate only a few pulses of position error, but a fully loaded motor will accumulate 2/3 of the pulses necessary for current limit. Loads between no load and full load will accumulate some number between 0 and the full load value. The maximum number of error pulses which may accumulate is about 100 (this is an adjustable "gain" function) at which time the brushless drive will be in current limit. When the maximum number of pulses are accumulated, the control is in current limit and further reference pulses will be ignored until the motor turns far enough to eliminate the excess pulses in the counter.

As long as the current limiting condition is avoided, the motor can track the reference frequency pulse for pulse. **IT IS IMPORTANT TO NOTE THAT, SHORT OF CURRENT LIMIT, THIS PULSE ACCUMULATION DOES NOT AFFECT SPEED.** It only affects the shaft position relative to the no load shaft position. Most motors talk about speed regulation in terms of revolutions per minute difference between set speed and actual speed. A brushless DC motor set to run at 1750 RPM (with a frequency reference), will be running at 1750 RPM, period.

For motors operating at a steady speed and at a steady load, the pulse accumulation will not change, staying at the value necessary to drive that load at that speed. If the load should change, the pulse accumulation in the up/down counter will change to a value necessary to drive the new load. If the speed changes, the pulse accumulation will not change if the torque required by the load is the same at the new speed as the torque required at the old speed.

This is a brief, very simplified, introduction to the operation of brushless D.C. motors. It does not and cannot cover all the points necessary for a full or complete understanding. There are books available on the subject of Brushless DC motors.

POWERTEC manuals contain a great deal of information and further understanding will come also with use of the motors and controls.

1.4 BRUSHLESS MOTOR BENEFITS

POWERTEC Industrial Corporation manufactures Brushless DC motors and controls for the *industrial* environment. Other manufacturers produce brushless DC motors for some specialized applications, but only **POWERTEC** makes a full line of Brushless DC motors and controls **from fractional to 600 Horsepower** for use on industrial power sources (230, 380, and 460 VAC three phase) in standard NEMA (National Electrical Manufacturers Association) frame sizes at prices competitive with conventional DC and Adjustable Frequency AC, including vector.

Some important benefits of using **POWERTEC** Brushless DC motors and controls are:

ABSOLUTE SPEED CONTROL REGARDLESS OF LOAD -- The speed regulation of the **POWERTEC** Brushless DC motor and control system is **0%**! The speed of the motor does not change from no load to full load. Options include a speed accuracy of 50 PPM (parts per million) and absolute ratio control.

INCREDIBLY HIGH EFFICIENCY -- The efficiency of the **POWERTEC** Brushless DC motor and control exceeds that of either conventional DC or induction AC motors and inverters. The Brushless DC motors are often in smaller frames than comparable motors. This efficiency contributes to low cooling costs for rooms where Brushless DC motors are installed as well.

VERY LOW MAINTENANCE -- The **POWERTEC** Brushless DC motor is as rugged and reliable as the AC induction motor. There are no brushes to change, no fields to burn up, and no commutator to be maintained. The bearings are long-life bearings, capable of *years* of operation with only regular lubrication.

ABSOLUTE TRACKING -- Two motors can be set up to track pulse for pulse. Their shafts will be very nearly synchronized. This capability is *standard*. Options include the ability to operate at an absolute ratio from 0.0001 to 7.9999.

The **POWERTEC** Brushless DC motor and control provide performance *in their standard configuration* which exceeds the performance of other types of motors and controls. Even when the other types of motors and controls are combined with expensive added cost options, they do not perform as well as the Brushless DC motor and control do right out of the box.

1.5 HOW TO USE THIS MANUAL

This manual is arranged into sections covering all of the stages of using the Model 4000:

- 1.0 Orientation to product.
- 2.0 Specification
- 3.0 Installation/Layout
- 4.0 Wiring/Design
- 5.0 Startup
- 6.0 Troubleshooting
- 7.0 Maintenance
- 8.0 Performance options

Reading of the entire manual will assist in understanding of Brushless DC motors and controls. While there are no schematic diagrams of the boards used in the Model 3500 in this manual, there are plenty of block diagrams and simplified diagrams which will help the person using this manual to observe and understand what is going on, and to isolate problems to the board level, if and when they should occur.

If any questions about this manual arise, contact your distributor, representative, or **POWERTEC** directly.

MOUNTED ON BACK OF PLATE

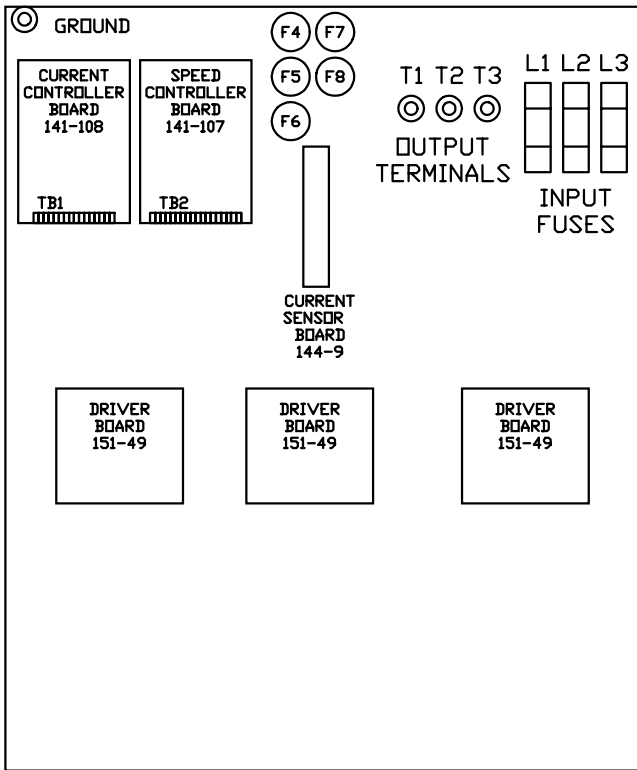

UPPER LEVEL

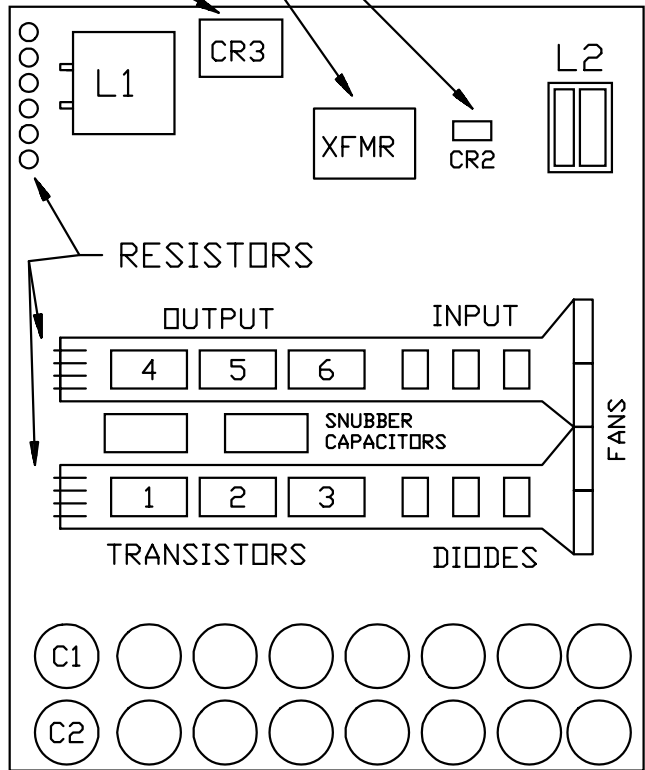

CHASSIS LEVEL

Figure 10: Parts layout of the Model 4000 Brushless DC motor control.

2.0 SPECIFICATIONS

2.1 ELECTRICAL RATINGS

LINE VOLTS VAC	HORSE POWER	KILO WATTS	APPROX LINE CURRENT AAC RMS	MAXIMUM MOTOR CURRENT AAC RMS	MAXIMUM HEAT OUTPUT WATTS	MAXIMUM HEAT IN BTU/HR	TRIP * CALIBRATE RESISTOR OHMS	HP ** CALIBRATE RESISTOR OHMS	HALL SENSOR STYLE CSLA1_ _
230	60	45	135	220	2450	8361	22 K	6.34 K	DK
230	75	56	163	270	3030	10342	39 K	5.36 K	DK
380	100	75	125	235	2675	9130	22 K	5.90 K	DK
380	125	93	165	272	3150	10751	39 K	5.36 K	DK
460	100	75	107	223	2041	6966	10 K	7.15 K	DK
460	125	93	134	223	2551	8706	22 K	6.34 K	DK
460	150	112	160	265	3062	10451	39 K	5.36 K	DK

* Trip resistor is on Current Sensor board TB3 terminals 1 and 2; OPEN means no resistor is needed. All resistors are 1/4 watt, 1%.

** HP calibration resistor is on Current Sensor board TB3 terminals 4 and 5; All resistors are 1/4 watt, 1% tolerance.

Hall Sensor style refers to part number of Hall Effect Current Sensors. The number is on the sensor.

2.2 DIMENSIONS

Model 4000 chassis 39.00"H x 33.00"W x 13.00"D (991mmH x 838mmW x 330mmD) Weight = 242 lbs (110 Kg)

Model 4000 NEMA 1: 42.06"H x 36.06"W x 16.06"D (1068mmH x 916mmW x 408mmD) Weight = 297 lbs (135 Kg)

Model 4000 NEMA 1A: 60.06"H x 36.06"W x 16.06"D (1524mmH x 914mmW x 406mmD) Weight = 325 lbs (147 Kg)

Standard dimensions and weights do not include options.

Nema 1 listed does NOT include space for options. Nema 1A has space for options.

2.3 ENVIRONMENTAL

ALTITUDE:	Use above 3300 ft (1000 m) requires derating
AMBIENT TEMPERATURE:	
Chassis	55°C (131°F) maximum
NEMA 1	40°C (104°F) maximum
INPUT VOLTAGE TOLERANCE:	+10%, -5% at all times
INPUT POWER FREQUENCY:	48 to 62 Hertz
RELATIVE HUMIDITY:	95% (non-condensing)
SERVICE FACTOR:	1.0
MAXIMUM SERVICE CAPACITY:	100 KVA (limited by input fuses AIC rating)
STORAGE TEMPERATURE:	-40°C to +65°C

2.4 PERFORMANCE

MAXIMUM LOAD:	125% for 1 minute out of 10 minutes
SPEED REGULATION:	0% (no load to full load)
SPEED ACCURACY:	(percentages referred to set speed over 100:1 speed range)

Analog Mode:	+/- 1.0% (typical with speed pot supplied by internal reference)
linearity: +/- 0.5%	(typical from external reference source)
Digital Mode:	0% (+/- 3/4 revolution of motor shaft)
DISPLACEMENT POWER FACTOR:	0.96

2.5 CUSTOMER ADJUSTMENTS

ACCELERATION TIME:	2 to 30 seconds, linear, analog mode		
DECELERATION TIME	2 to 30 seconds, linear, analog mode		
MAXIMUM SPEED:	600 to 5000 RPM, motor dependent		
JOG SPEED:	0 to 30% of maximum speed, analog mode only		
CURRENT LIMIT:	0 to 150%, resistor calibrated		
GAIN RANGE:	10 to 1		
STABILITY:	20 to 1 dynamic range		
MINIMUM SPEED:	0 to 15% (with 5K speed pot)		
JUMPERS	JP1	IN: ramp to stop	OUT: coast to stop
	JP2	IN: standard accel and decel	OUT: 50 millisecond accel and decel

2.6 INDICATORS

Current Controller board
HS1, HS2, HS3 (encoder)
 Low level **POWER**
OVervoltage/**UN**dervoltage
 Power Loss
 Instantaneous **Over Current**
BUSS (charging/ready)
ENABLE

Speed Controller board
RUN
 Current Limit
 Zero Speed

Base Driver board
 Base Drivers (6)

Current Sensor board
 UnderVoltage
 Undervoltage Time Out
 OverVoltage
 Heatsink OverTemperature
TherMaL
RELAY ON

2.7 TERMINAL DESCRIPTIONS

TB1 Current Controller Board (141-108)

1	Shields and Ground connection
2	HS1 position encoder
3	HS3 position encoder
4	HS2 position encoder
5	HS4 speed encoder
6	HS5 speed encoder
7	Common for encoder ONLY
8	+5 VDC for encoder ONLY
9	Common for terminals 10 and 11
10	Auto/Manual Selection +24 VDC
11	External Frequency Input +24 VDC
12	Collector of FAULT transistor
13	Emitter of FAULT transistor
14	Load output (-2VDC = 150%)
15	Auxiliary Supply output
16	Power Common

9	+10 VDC reference supply
10	Speed reference input 0 to +10VDC
11	Minimum speed connection for speed pot
12	Signal common
13	Jog input +24VDC to JOG
14	Forward/Reverse input +24VDC to reverse
15	Frequency output open collector to common
16	Zero speed output open collector to common
17	+24VDC raw supply 50 mA max
18	Current reference 0 to +10VDC (velocity error)

TB3 Current Sensor Board (144-9)

1	Trip calibration resistor
2	Trip Calibration resistor
3	RTO output
4	Horsepower calibration resistor
5	Horsepower calibration resistor
6	Motor Thermal input
7	Motor Load output (-10VDC = 180%)
8	Common
9	-24 VDC
10	Contact control

TB2 Speed Controller Board (141-107)

1	RUN contact (closes on RUN)
2	RUN contact 1 Amp 125 VAC
3	-24 VDC raw supply 50 mA max
4	RUN input +24VDC to RUN
5	RUN hold (junction of RUN and STOP)
6	SPARE (tie point for motor thermal)
7	Emergency STOP +24VDC to RUN
8	+24 VDC RUN Logic Supply 50 mA max

3.0 PHYSICAL INSTALLATION

3.1 RECEIVING

POWERTEC products are packed carefully for shipment, but occasionally damage may occur between the factory and the site at which the equipment will be installed. When the equipment is first received, a physical inspection should be made of the shipment to determine if there is any visible physical damage which may have occurred in shipping. If inspection is put off until later, damage discovered may delay installation.

If damage is found, notify the carrier of the equipment immediately. Equipment is shipped F.O.B. the factory. Shipping claims must be filed by the receiver directly to the carrier. **POWERTEC** will assist claims with information necessary to assess and repair damage.

In unpacking, be sure to remove all packing materials, since materials left in the control or motor may interfere with air flow necessary to cool the equipment.

DO NOT THROW AWAY THE MANUALS, CONNECTION DIAGRAMS, OR OTHER INFORMATION SENT IN THE SHIPPING CONTAINER

3.2 BEFORE INSTALLATION

Improper lifting practices can cause serious personal injury. Use proper equipment to move materials.

DANGEROUSLY HIGH VOLTAGES ARE NORMAL IN THIS EQUIPMENT! WHEN POWER IS REMOVED, THE CAPACITORS ARE NOT DISCHARGED AT ONCE! BE SURE THE INPUT POWER IS OFF AND THE CAPACITORS ARE DISCHARGED BEFORE WORKING ON THE MOTOR OR THE MOTOR CONTROL.

POWERTEC's Model 4000 has been completely tested at the factory and is built to standards applied to all **POWERTEC's** other drives. This testing is done to ensure safety of the basic unit. It is the responsibility of the user of this equipment to ensure that the installa-

tion complies with all other national, state, and local codes which apply to this equipment and to the installation. This applies to grounding of the motor, motor control chassis and enclosures as well.

The use of external circuitry or devices and peripheral equipment not supplied by **POWERTEC** as a part of the equipment, or equipment which is supplied separately by **POWERTEC** for wiring by the customer at the user's request, is done entirely at the user's risk.

DO NOT DISCONNECT, UNPLUG, OR REMOVE ANY CONNECTIONS ON THE MOTOR OR ON THE MOTOR CONTROL WHILE POWER IS APPLIED. SEVERE DAMAGE AND/OR PERSONAL INJURY MAY RESULT FROM THESE ACTIONS.

THE USE OF TEST EQUIPMENT ON THE MOTOR AND CONTROL IS VERY HAZARDOUS. THIS EQUIPMENT SHOULD BE SERVICED ONLY BY PERSONNEL EXPERIENCED IN THE SERVICING AND MAINTENANCE OF HIGH POWER ELECTRONIC EQUIPMENT! USE THE PROPER TEST EQUIPMENT AND PROCEDURES!

Do not use a megger on the electronic equipment without consulting the factory. If a megger is used on the motor or the wiring to the motor, disconnect the wiring from the control. DO NOT USE A MEGGER ON THE MOTOR ENCODER CABLE AT ANY TIME!

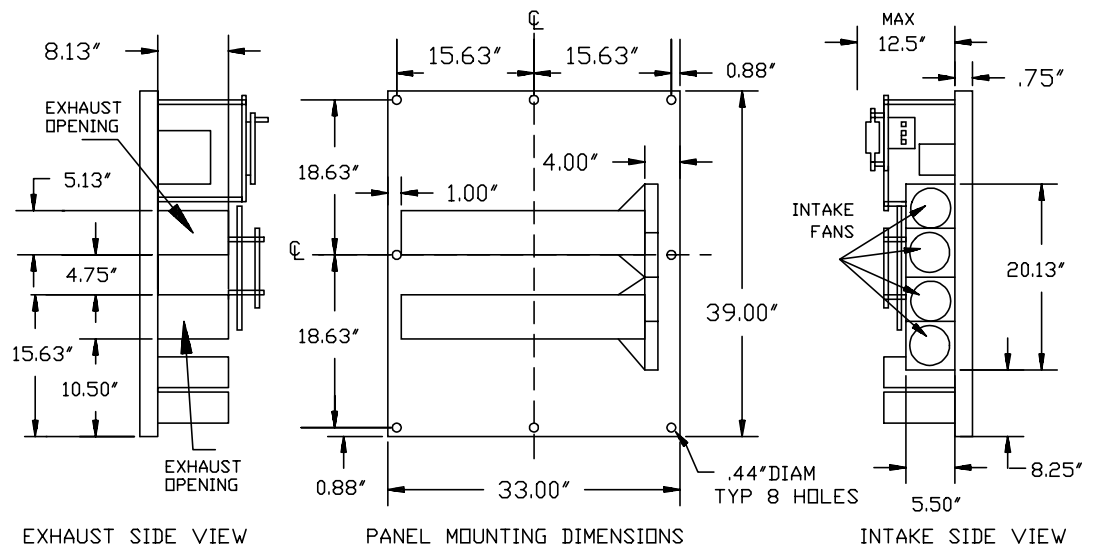

Figure 11: The mounting dimensions of the chassis version of Model 4000.

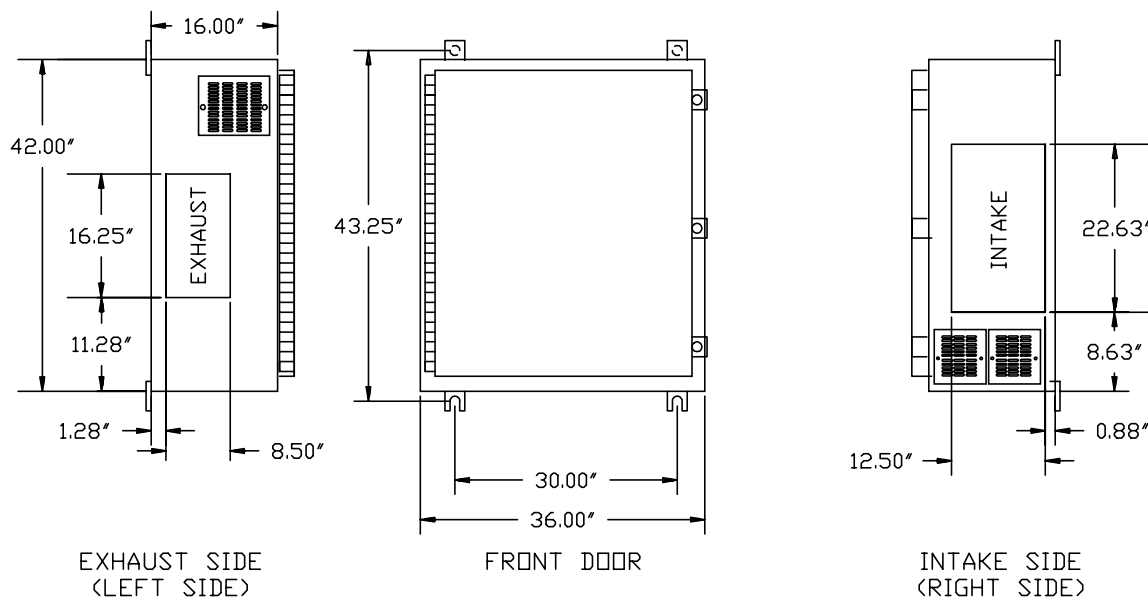

Figure 12: Physical dimensions of the NEMA 1 version of the **POWERTEC** Model 4000.

3.3 INSTALLATION

Figure 11 gives the basic dimensions of the 4000 chassis. The basic dimensions of the NEMA 1 version of the Model 4000 are shown in figure 12.

When mounting the chassis in an enclosure, care should be exercised to avoid handling the chassis by parts which may bend or come loose. This especially applies to the plexiglass cover of the unit. Try to support the chassis as much as possible by the outside edges of the heatsink.

WARNING! : IF THE CHASSIS HAS BEEN BENCH TESTED PRIOR TO INSTALLATION, CHECK TO MAKE SURE THAT THE BUSS CAPACITORS HAVE FULLY DISCHARGED BEFORE ATTEMPTING TO INSTALL THE CHASSIS.

3.4 THERMAL CONSIDERATIONS

The 4000 chassis may be mounted in a vertical position (fuses up) in a suitable enclosure. The Model 4000 may also be mounted "sideways" with the fans on the bottom. The ambient temperature of the air immediately surrounding the chassis may not exceed 55 degrees C (131 degrees F).

When the chassis is installed in an enclosure there must be at least 9" (150 mm) of free space on each side of the chassis, this space allowed for the proper air flow through the heatsink fans. The chassis must be mounted vertically to

promote air flow through the heatsink. Avoid mounting one chassis directly above another too closely with the result that hot air from the lower chassis flows directly up into the other chassis.

The NEMA 1 enclosure should be mounted vertically in an area which allows a free flow of air around the enclosure and some air flow around the back. Maximum ambient temperature of the air surrounding the NEMA 1 control should not exceed 40°C (104°F).

There must be at least 6" (150 mm) of free air space in all directions around the NEMA 1 enclosure. If there are two units mounted directly in line vertically, there should be at least 12" (300 mm) between the units.

The size of the enclosure for the chassis units is determined by the total heat dissipation within the enclosure. The heat output of the controls is given in section 2.1 on page 9. Enclosures which use air flow for cooling (NEMA 1, 1A, and NEMA 12 ventilated) must have an air flow of 1 CFM (cubic feet per minute) for each 10 watts of dissipation (1 cubic meter /minute for each 350 watts).

Totally enclosed units (NEMA 3,4, or 12) must allow 1 square foot of enclosure surface area (including front, sides, top and bottom surface areas) for each 7 watts of dissipation (75 watts per square meter).

For further information, consult **POWERTEC's** publication "THERMAL MANAGEMENT".

4.0 ELECTRICAL INSTALLATION

After manufacturing and testing, the most important time in the useful life of a motor or motor control is the installation process. Decisions are made, or not made, on all of the considerations which are to be involved in the environment in which the motor and control will spend their operational life. Issues ignored during installation are sure to crop up at a later time, and the time and manner in which they crop up may be very inconvenient and/or very painful, not to mention very costly.

4.1 GENERAL REQUIREMENTS

POWERTEC motors and controls require no more care and concern in the installation than any other **precise** motor and control, although they do require more consideration of the environment than run-of-the-mill motors and controls which do no more than run a motor, period. If superior performance is expected, then it is normal to expect superior care in installation.

One of the most frequent problems encountered with digital type equipment is electrical noise. Noise is an insidious problem which is capable of causing not only destructive problems, but also intermittent, annoying problems. The methods used in the installation of the equipment plays a large part in prevention of electrical noise interference in the operation. *Any digital type control requires that extra care be taken in the grounding of the equipment, the shielding of wires and cables and placement of wires in the conduit runs.* Pay attention to the sections which address the precautions against noise, whether in the control, in the motor, in the wiring, or in any auxiliary equipment. Follow the directions of other manufacturers for other equipment that come with the other equipment to be used in the system.

4.2 POWERSUPPLY

The **POWERTEC** Model 4000 Brushless DC motor controls requires a source of three phase input power with a KVA rating at least equal to its horsepower rating. The branch service rating (in KVA) supplying the control should not be more than 10 times the rating of the control, or special disconnecting means ratings or sizes may be required.

An ISOLATION TRANSFORMER is not necessary for the operation of the **POWERTEC** Brushless DC motor control, but, if it is desired to use one, or if one is required by local code requirements, it should be sized (in KVA) at least as large as the horsepower rating of the motor control.

The fuses which are supplied on the input of the Model 4000 Brushless DC motor control are designed to protect the semiconductor elements of the unit. THEY MAY OR MAY NOT MEET THE REQUIREMENTS OF NATIONAL, STATE AND/OR LOCAL CODES.

The responsibility for meeting the branch service protection and other code requirements of national, state and local codes belongs to the user.

Since **POWERTEC** controls are supplied without input disconnects, the user must supply a disconnecting means which meets applicable code requirements. The maximum interrupting capacity (AIC) of the fuses on the input of the Model 4000 is 200,000 amperes. If the maximum short circuit current available on the service is greater than this, a disconnect with an AIC rating greater than 200,000 amperes will be required.

Wire sizes for the input of the control *may be determined* by the fuse sizes on the control. The output current of a Brushless DC motor control **is always greater than the input current.** Check the nameplate of the control for input current requirements and output current limitations. Check the motor nameplate for its required current.

NOTICE: THE INPUT CURRENT OF THE BRUSHLESS DC MOTOR CONTROL IS NOT REPRESENTATIVE OF THE LOAD CURRENT ON THE MOTOR! The input current is representative of the **POWER** output of the motor. **The only point at which the input AC line current reaches its full value is when the motor is operating at full speed with full load. DO NOT ATTEMPT TO MEASURE MOTOR LOAD BY MEASURING THE AC INPUT LINE CURRENT TO THE BRUSHLESS DC MOTOR CONTROL.**

The tolerance of the input voltage to the Brushless DC motor control Model 4000 is plus ten percent (+10%) to minus five percent (-5%) of the nominal voltage listed on the nameplate of the control. Measuring the voltage at the input to the control when the control is off neglects the effects of load on the power source. The actual input voltage to the control should be measured while the control is operating the motor in a loaded condition.

Transient power line disturbances of a minor nature will not normally disturb the motor controls. There is a built in ability to "coast through" an interruption of AC power of up to 80 milliseconds. Nor does the Model 3500 generate significant noise back onto its power service.

Any effects which tend to distort the AC waveform may, however, be detected as an under-voltage or phase loss condition. Some types of motor controls with diode front ends may

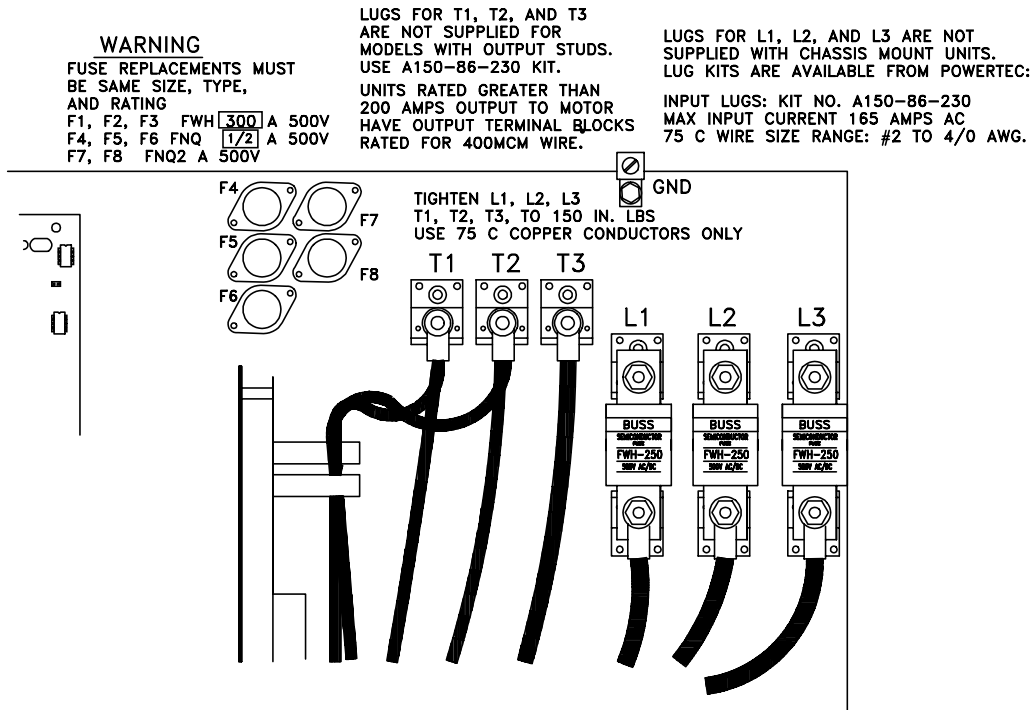

Figure 14: Input power fuses and output connections of the Model 4000..

tend to flatten the peak of the AC sine wave, causing the peak voltage to be significantly less than it should be. This is usually caused by a service which is not stiff enough to supply the connected capacity or by external line impedances which cause excessive voltage drops in the feeders.

A service which supplies the Model 4000 as well as AC motors must be capable of supporting the starting current of the motors without dropping more than 5%.

The power source also must be capable of supporting a current limit condition for short periods without pulling down the input voltage below the low voltage threshold. Otherwise trips will occur.

4.3 CONNECTING THE MOTOR

4.3.1 Motor Leads

A wiring card for STANDARD CONNECTIONS is supplied with every drive shipped from the factory. It shows how to connect the Brushless DC motor to the motor control. It is vitally important that the connections to the motor be made properly. Figure 13 on page 14 is a reproduction of the connection card. Figure 14 is a drawing of the power input fuse and motor output connection area of the Model 4000, showing the location of the other fuses.

The wires to T1, T2, and T3 on the control must be connected to the corresponding connections of the motor. If these wires are not in the proper order, the motor will not operate. If any of these connections should open up, the motor

will run erratically, if at all. The motor leads marked T1, T2, and T3 will always connect to T1, T2, and T3 on the control, although the other motor wires connected with T1, T2, and T3 at the motor will vary with the connection of the motor windings. There may be other wires connected to T1, T2 and T3 at the control, such as Dynamic Braking wiring, if the DB option is installed.

4.3.2 Motor Ground

A ground connection may be picked up at any bolt or screw in the motor junction box, and this ground connection needs to be run to the control with the motor power wires and connected to the same ground as the control's ground. The control ground must be connected to earth ground as close as possible to the power ground.

THIS GROUND WIRE MUST BE RUN IN ADDITION TO THE GROUNDING OF THE MOTOR FRAME TO ITS MOUNTING.

The purpose of this separate ground is to equalize the potential between the motor's frame and the control chassis. Though the motor may be grounded to its mounting frame, and the frame may be connected to a ground, there may be enough impedance between the motor and the control chassis to broadcast EMI and RFI. A direct wire connection between the motor frame and the drive chassis will minimize the effects of RFI and EMI.

4.3.3 Output Contactor

If an output contactor is used with the Model 4000 motor control, provisions **MUST** be made in the control circuits to interlock the output contactor with the Emergency Stop circuits. **If the output contactor is not properly interlocked with the motor control, damage to the motor control WILL result.**

The requirements are:

1. The contactor must close the main power contacts **BEFORE** the drive is enabled; **AND**
2. The contactor may only open its contacts **AFTER** the drive is disabled.
3. The contactor must be able to carry the rated motor current, but is not required to make or break higher levels of current, as AC motors must do.

Figure 15 shows the plan for connections for using a separately powered output contactor (which is available from **POWERTEC**) with the Model 4000 control. In this configuration, the contactor will energize when there is a run command and de-energize **ONLY** on an emergency stop. The contactor will stay energized during normal stops.

POWERTEC makes available a track mount PC board (Part # 156-012) with the circuitry shown for sequencing of output contactors and dynamic braking contactors..

DO NOT break the ground connection or the cable connections with the output contactor.

It is strongly recommended that a maintained type of Emergency Stop button (twist or pull to release) be used in any Emergency Stop system.

ALWAYS BE SURE THAT EMERGENCY STOP HAS BEEN ACTIVATED BEFORE GOING NEAR DRIVEN EQUIPMENT USING AN OUTPUT CONTACTOR CONNECTED AS SHOWN.

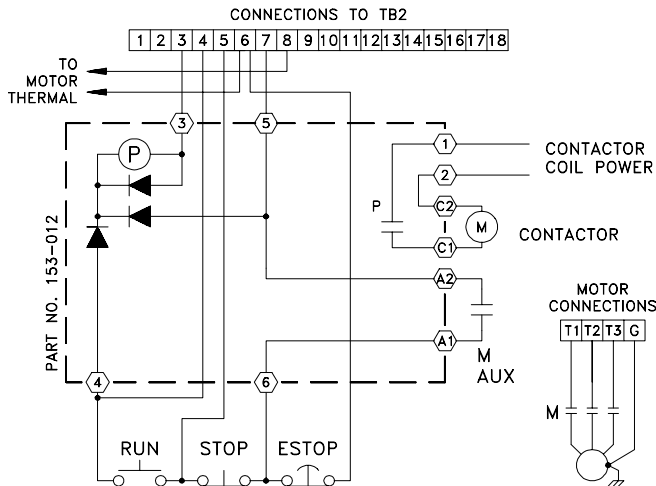

Figure 15: Connecting an output contactor with an externally powered coil to a Model 4000.

4.3.4 Motor Feedback Cable

The encoder feedback cable must be a shielded cable. See figure 8 on page 14 for shield connections at the motor end. The shield is connected to TB1 terminal 1 on the control end. Standard installation calls for a nine conductor shielded cable (Belden part #9539 or equivalent). The colors of this cable correspond to the colors of the wires in the motor and on the connection diagram. The Purple and White wires may be interchanged without ill effect. Likewise, the connections on TB5 terminals 1 and 3 may be reversed without difficulty.

If the motor thermal protector is to be used in a 120 VAC circuit, it should be run in wiring outside of the cable, and seven conductor shielded cable may be used. In this case, if the cable wire colors are different from the diagram, they need to be checked carefully to be sure that the proper connections are made. Also the shield must be continuous all the way from the motor to the control. (Do **NOT** ground the shield at intermediate points). This applies to all junction boxes which may be installed between the motor and control.

DO NOT USE THE SHIELD OF THE ENCODER CABLE AS AN ACTIVE CONDUCTOR !

4.4 CONTROL CONNECTIONS

The control circuits of the **POWERTEC** Brushless DC motor controls operate on 48 VDC. This voltage is derived from the raw +24 VDC (with respect to common) and the raw -24 VDC supplies. Using 48VDC tends to balance the load of relays and other devices on the supplies instead of placing the burden on one of the supplies, and requires less operating current than 24 VDC devices.

Some of the relays used with the Model 4000 must be 24VDC when used with open collector functions (see section 4.6). The maximum current from each of the raw supplies is 50 milliamps. Due to this supply limitation, when several 24 VDC external relays are used, they should be externally powered from a separate supply..

THE POWER SUPPLIES OF THE MODEL 4000 SHOULD NOT BE USED FOR EXTERNAL EQUIPMENT! POWERTEC has an optional power supply (part # 127-101) available to supply additional power.

It is possible to operate the control circuits with a variety of devices. Standard operator devices may be used, but the current flowing through these devices is very small. When control push-button and other operators are to be located more than 30 feet away from the motor control, the use of 120 VAC control circuits should be considered. The 120 VAC relays must be run by a customer supplied transformer, and normally open and normally closed contacts substituted for the normally open and normally closed contacts shown in the connection diagram (figure 13). Take note in the last section of the use of 120 VAC on the motor thermal.

EMERGENCY STOP	TB2-7 and TB2-6 **	Must be closed to RUN. Enables RUN circuits on closing. On opening, disables all control functions immediately. DO NOT JUMPER THESE TERMINALS, especially if the RAMP STOP jumper is installed!
MOTOR THERMAL	TB2-8 and TB2-6 **	Normally closed thermal switch in the motor.. Acts like E. Stop on opening if the control circuits are wired in the standard configuration shown in figure 14. THE MOTOR THERMAL SWITCH MUST BE CONNECTED IN ORDER TO PROTECT THE MOTOR PROPERLY!.
RAMP STOP	TB2-7 and TB2-5	Must be closed to run. On opening, drive will ramp to zero speed if RAMP STOP jumper is installed and control is in analog mode. Otherwise, motor will coast to a stop. In digital mode frequency input must be reduced to zero.
RUN	TB2-5 and TB2-4	Momentary close to run. Must be open if momentary STOP is used to terminal 5. RUN relay CR latches between the terminals if terminal 5 is energized. Must be held closed if two-wire connection is used (4 and 7).
RUN CONTACT	TB2-1 and TB2-2	Closes when terminal 4 is energized. Stays closed as long as relay CR is maintained by RAMP STOP button on terminal 5, or two-wire connection maintains connection on terminal 4. DOES NOT OPEN ON FAULT!
ZERO SPEED	TB2-16 and TB2-12	Open collector transistor, C on 16, E on 12. Rated at 50 mA @ 50VDC. Turns on above 10 RPM and off below 10 RPM. May chatter at very low speeds.
JOG	TB2-5 and TB2-13	Starts control in JOG mode (no latching). The control operates while JOG circuit is closed. Speed set by pot on board if in analog mode, otherwise frequency must be supplied. JOG OVERRIDES RUN!
REVERSE	TB2-8 and TB2-14	Close in analog mode to cause motor to go to zero speed and return to set speed in the opposite direction. Open to do same thing in opposite direction. May be applied at any speed. Does not work in digital mode unless input frequency is reduced to zero..
FAULT OUTPUT	TB1-12 and TB1-13	Isolated optocoupler transistor, C on 12, E on 13. Rated at 50 mA @ 80 VDC. Turns on when buss is at proper level. Turns off on trip condition.
ANALOG / DIGITAL SWITCH	TB1-10 and TB1-9	Apply +24 VDC at terminal 10 with respect to terminal 9 to change from analog to digital mode. Frequency must be applied at terminal 11 with respect to terminal 9.
** NOTE: TB2 terminal 6 is a "dead" terminal which has no connection on the board and is used as a tie point.		

Table 1: Control circuit connections for the Model 4000.

Table I is an explanation of the connection and function of the control circuits of the Brushless DC motor control. Read the descriptions of the operations of the circuits carefully, since there are some differences between the operations in the analog and digital modes.

In some installations there is a temptation to place a jumper across Emergency Stop terminals, rather than to install ESTOP buttons. This could set up an UNSAFE situation. **IT IS STRONGLY RECOMMENDED THAT THE EMERGENCY STOP BUTTON (or ESTOP relay) BE INSTALLED ON THE 4000!** They have a ramp stop function which causes the motor control to decelerate the motor (in the analog mode) to zero speed before shutting off. (In digital mode, the external frequency must be reduced to zero for this function.) Even if the RAMP STOP jumper is removed in a particular installation, a replacement board or control may be put in at a later date with the jumper installed, creating a safety problem. If the control does not stop when the RAMP STOP is pushed, for any reason, the Emergency Stop is the only way to stop it, short of removing power from the control.

The motor thermal must be used to adequately protect the motor from overheating. The motor thermal on the **POWERTEC** Brushless DC motor is able to protect the motor because it is located where the heat is produced in the motor, in then stator windings. Very little heat is produced in the rotor of the Brushless DC motor.

Many of the control functions are changed slightly when the drive is changed from the analog to the digital mode. The analog mode uses the analog reference input (TB2 terminal 10) to set speed. In digital mode they look for an external frequency at TB1 terminals 11 and 9 (see section 4.5), and ignore the level of the analog input. It always looks at TB2 terminal 14 for the direction of rotation (forward or reverse).

The use of "two wire" control between terminals 7 and 4 on TB2 DOES NOT disable the RAMP STOP function. The only way to disable the RAMP STOP function is to remove the RAMP STOP jumper.

The RAMP STOP function in the analog mode shorts the analog reference input to zero, causing the motor to decelerate to zero speed before shutting off. In digital mode, the external frequency must be reduced to zero for the RAMP STOP to function. **POWERTEC's** DIGIMAX IV takes care of this function when it is installed according to standard connections (see page 38), but in other configurations the system designer must make sure that the frequency goes to zero. The external frequency may simply be taken away (such as by the opening a relay contact), in which case the motor will coast to zero speed and then the control will shut off.

The zero speed output may "chatter" at low speeds, particularly when the motor is unloaded. This may be overcome by using the zero speed relay as a holding contact (see section 4.6)

Note that the JOG function OVERRIDES the RUN function. If the JOG input (+24 VDC at terminal 13 is activated while the in the RUN mode, it will be ignored.

In analog mode, the JOG speed is set by the on board pot (acceleration in current limit), but in digital mode the speed is set by the external frequency (see section 5.1.7 for setting motor direction in Jog). RAMP STOP is active during the JOG mode, but deceleration time will be determined by the "coast time", since the speed signal from the on board JOG potentiometer bypasses the accel/decel circuits. In digital mode, the accel rates is set by the rate of change of the external frequency, or current limit, if the rate is too fast. The decel rate in digital mode will be determined by the "coast time" (see section 1-2) if it is longer than the decel time set.

4.5 REFERENCE OPTIONS

There are options available for speed control of the **POWERTEC** Models 4000 Brushless DC motor control. They break down into two types: ANALOG and DIGITAL. Both types are contained in the basic control. The selection is made by the application of +24 VDC at TB1 terminal 11 with respect to TB1 terminal 9. This is an optically coupled input which is not referenced to the control common.

4.5.1 Analog reference

Analog speed control is the most common type used for motors and controls. The Model 4000 has a positive 10 VDC speed references built in. The reference source is accurate within 1%.

The analog control of speed consists of supplying a 0 VDC (for zero speed) to +10 VDC for full speed forward or reverse. Directional selection is made at TB2 terminal 14.

This analog signal is applied to TB2 terminal 10 with respect to TB2 terminal 12, which is the signal common of the motor control.

This analog signal might come from a speed potentiometer which is connected to include the use of the minimum speed potentiometer on the Speed Controller board:

High side of pot
TB2 terminal 9 (+10 VDC source)
Wiper of pot
TB2 terminal 10 (reference input)
Low side of pot
TB2 terminal 11 (common)

The speed potentiometer may also be connected for operation *without* a minimum speed adjustment:

High side of pot
TB2 terminal 9 (+10 VDC source)
Wiper of pot
TB2 terminal 10 (reference input)
Low side of pot
TB2 terminal 12 (common)

Of course, in the analog speed mode, any 0 to +10 VDC reference signal will act as a speed command as long as it is referenced to TB2 terminal 12, and the direction of rotation will depend upon the polarity of the voltage at TB2 terminal 14 with respect to TB2 terminal 12 in the analog speed mode.

Input voltages greater than +10.6 VDC or -0.6 VDC are clamped by the input circuits. Nominal input impedance for voltages less than +10VDC is 50Kohms. Potentiometers used for speed pots should be no less than 2 Kohm (reference supply limitation, and not greater than 10K. Above 10 Kohms the pot is non-linear, so a setting of 50% may give a speed of 47%. This is especially true with multi-turn potentiometers, when non-linearity is made most noticeable by the dial reading.

When a manual speed potentiometer which is supplied by TB2 terminal 9 is used, the speed accuracy (versus reference) of the control will be dependent on the stability of the reference source and temperature and noise effects. This is generally better than 1% after the drive and motor have reached their operating temperatures.

If an external reference source is used, the control will track the input voltage at TB2 terminal 10 within +/- 0.5%. The tolerances of analog circuitry determine how well the control will do with an analog reference. While the above numbers represent the worst cases, typical speed accuracy performance in a load and temperature stabilized system can be expected to be better than 0.1% of setpoint.

In analog mode of operation, maximum motor speed in relation to the applied reference is determined by adjustment of the MAX SPEED potentiometer on the Speed Controller. This pot calibrates the motor speed for the applied reference. The brushless DC motor, by itself, will not exceed its base speed by very much when it is heavily loaded. It is possible that, if the MAX SPEED pot is turned up too far, and the load is light, it will seem to have no effect. The maximum speed of the motor will not be attained until the motor has reached operating temperature. Like any NEMA standard DC motor, a warm-up time is necessary to reach operating temperature, due to the fact that a cold motor develops more CEMF (and therefore more torque). The MAX SPEED adjustment has no effect in digital mode.

The on-board JOG pot is analog. It is activated by the JOG circuit, which overrides the RUN circuits. The on board JOG pot does not determine the JOG speed while the control is operating in the DIGITAL MODE.

It is not necessary to reduce the input reference to zero before starting or stopping the drive. The reference input circuits and the accel/decel circuits are clamped while the control is stopped. The clamp is released when the RUN is activated. The clamp is turned on also for the RAMP STOP function. The speed pot may be left at its speed setting, or an external reference may be left connected while the control is decelerating during the RAMP STOP function, or while the control is stopped. When RUN is restored, the control will accelerate at the Accel rate.

4.5.2 Digital Reference:

Since the Brushless DC motor control system is inherently digital, the performance in the digital mode of operation far exceeds the performance in the analog mode. In the digital mode the control and motor respond to a frequency signal which is fed to the control from an external source.

In the digital mode the same digital control circuitry is used for the speed control as is used in the analog mode. The analog output of the accel/decel circuits drives a voltage-controlled-oscillator (VCO), which in turn feeds the digital

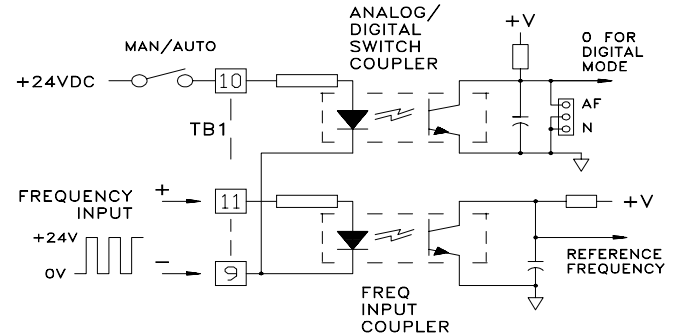

Figure 16: Analog/digital switch and frequency input circuits of the **POWERTEC** Brushless DC motor control.

circuitry. In digital mode the VCO is bypassed and an external reference frequency is used to control speed.

The digital mode is activated by applying a nominal +24 VDC voltage to TB1 terminal 10, positive with respect to TB1 terminal 9 (figure 16). There is also a jumper next to P2 on the Current Controller board (141-108) which, when placed in the AF position of the jumper, switches the control into the digital mode without energizing terminal 10 with an external voltage (see figure 32 on page 33).

Either of these actions disconnects the control's internal VCO and looks for a frequency at TB1 terminal 11, which must be positive with respect to TB1 terminal 9. This frequency signal must meet certain specifications:

- "ON" VOLTAGE: 18 VDC min, 30 VDC max
- "OFF" VOLTAGE: less than 1.5 VDC
- FREQUENCY: 2X desired RPM (250 frames or smaller)
- DUTY CYCLE: 25% min, 75% max
- MAXIMUM FREQ: 50 KiloHertz

The best tracking is gained by "ramping" the frequency, changing the frequency gradually. If a frequency is present when the control is turned on, the motor accelerates in current limit. The nature of the Brushless DC motor control is that the motor must return a pulse for each reference pulse supplied, **except in current limit!** If the control goes into current limit, pulses will be lost. So it is best to not change the external frequency so rapidly that the motor cannot respond without going into current limit.

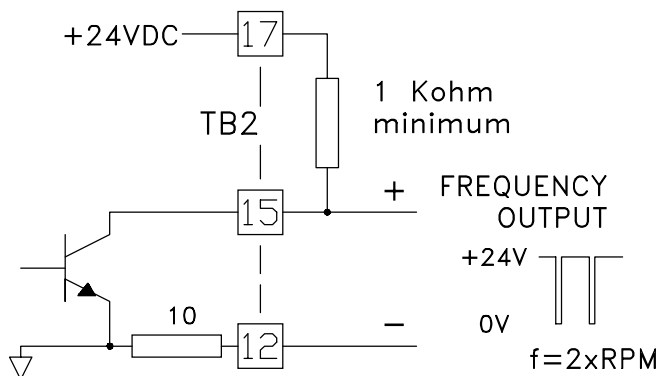

Figure 17: Connections for the frequency output of the Non-regenerative drive.

The frequency input for any **POWERTEC** motor control may come from another **POWERTEC** motor control, since there is a frequency output located on the Speed Regulator Board 141-107 (figure 17 shows the NON-REGEN drives connections).

Terminal 15 on TB2 is the collector of a transistor (TB2 terminal 12 is the common) which switches at twice the RPM of the motor. If a resistor (1 Kohm minimum) is connected from TB2 terminal 17 (+24 VDC) to TB2 terminal 15, a frequency signal will be generated which is capable of driving the input of another control. Connect TB2 terminal 15 on the first control to TB1 terminal 11 on the second control, and connect TB2 terminal 12 on the first control to TB1 terminal 9 on the second control. Connect TB2 terminal 17 on the first control to TB1 terminal 10 on the second control to switch it into digital mode.

With this arrangement (figure 18), the second motor will operate at exactly the same speed as the first, as long as current limit is avoided on the second control. If the first control encounters current limit, or changes speed for any other reason, the second one (the follower) will follow it down in speed, even to zero speed.

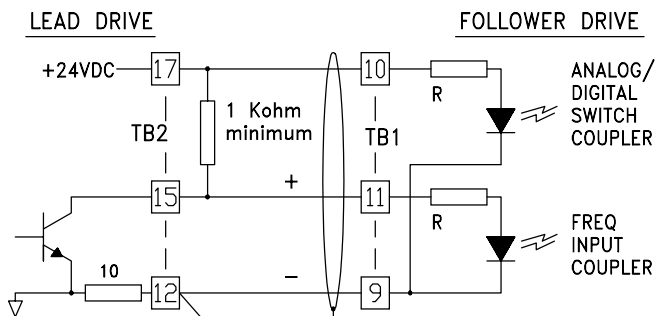

Figure 18: Connections for any other **POWERTEC** Brushless DC drive (except the Model 500) to follow a Non-regenerative drive at a 1:1 ratio.

4.6 AUXILIARY CIRCUITS

This section concerns relays which are *allowed* to be used with power from the Brushless motor control, as well as some other circuits. Only those relays listed in this section are authorized to be operated from the control's supplies. If any other relays are operated from the supplies, it is at the user's risk. **DO NOT USE MORE THAN TWO OF THESE RELAYS AT THE SAME TIME!** Auxiliary power supply boards (part # 127-101) are optionally available for powering any additional relays.

RUN RELAY

A 48 VDC small control type relay (coil current of 20 mA or less) may be connected to the brushless DC motor control in the manner depicted in Figure 13. The connections on the left of the terminals are located on the Speed Controller Board (part #147-101). The equipment to the right of the terminals are user connections. A relay to be recommended is a type equivalent to Potter & Brumfield part number KHU17D-11-48, which has a low current draw of 15 milliamps for a four-pole double-throw relay. The diode shown across the coil is necessary to prevent damaging transients when the relay shuts off. **DO NOT OPERATE THIS CONFIGURATION WITHOUT THE DIODE.**

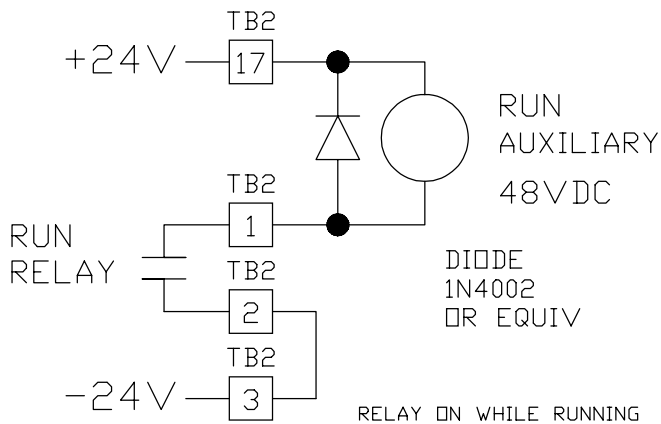

Figure 19: Connections to add an auxiliary **RUN** relay to the control.

It is a good idea to keep the coil current as low as possible when connecting relays to the control. Using an auxiliary relay makes additional RUN contacts available (there is only one on the board), and allows the use of one of the contacts to interlock the JOG button to prevent activation of the JOG circuit while operating in the RUN mode.

When distances of more than 30 feet are involved, it is advisable to use 110 VAC control relays for an operating interface to the controls.

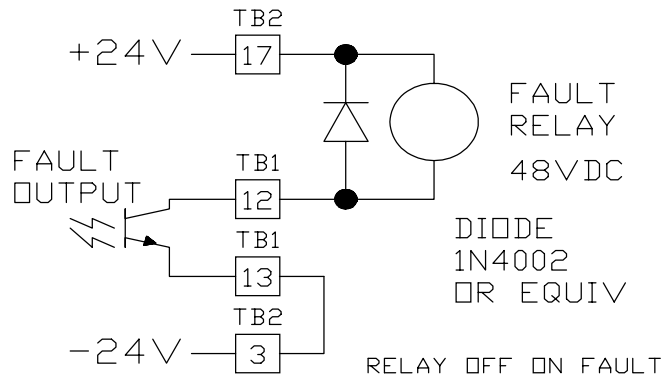

Figure 20: Adding a FAULT relay.

FAULT RELAY

A 48 VDC relay may be connected to the **POWERTEC** brushless DC motor control in the manner shown in Figure 20. Using an auxiliary relay makes fault contacts available to 120 VAC control circuits (the fault output of the board is the output transistor portion of an optical coupler, and the optical coupler can only operate direct current circuits up to 50 VDC at 50 milliamps). The diode around the coil of the fault relay is necessary for surge protection.

The fault circuits are designed to be fail safe. If there is no fault, the relay is energized. If the relay should fail for any reason, the relay will be off, indicating a fault.

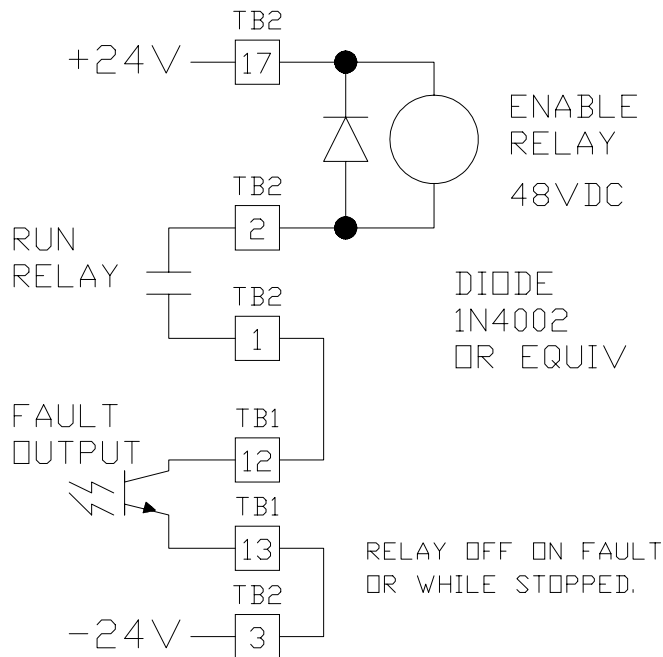

Figure 21: Obtaining an ENABLE indication.

ENABLE RELAY

On the **POWERTEC** Model 4000 there is a way to obtain an *enable* relay output which combines the functional effect of the RUN and the FAULT relays.

The RUN relay is pulled in by the application of +24 VDC to TB2 terminal 4. The RUN relay will stay on as long as there is a sufficiently positive voltage on that terminal. The RUN relay **does not drop out when a trip occurs**. It only drops out when both terminals 4 and 5 on TB2 are open.

The FAULT relay pulls in when there are no faults (i.e., when the buss is charged up after application of power, or, after a previous fault is reset by pressing the STOP button). It only drops out after a trip occurs.

Neither the RUN nor the fault tells the user *by itself* that the control is actually in an operational state, but the combination of the two, when both are ON, says that the control is on and that there are no faults. This circuitry will shut off when the RUN circuit is dropped, even if the control is decelerating in RAMP STOP.

Figure 21 illustrates the wiring and connections to connect an ENABLE relay to the drive. The maximum current is 50 mA. The diode around the coil must be installed.

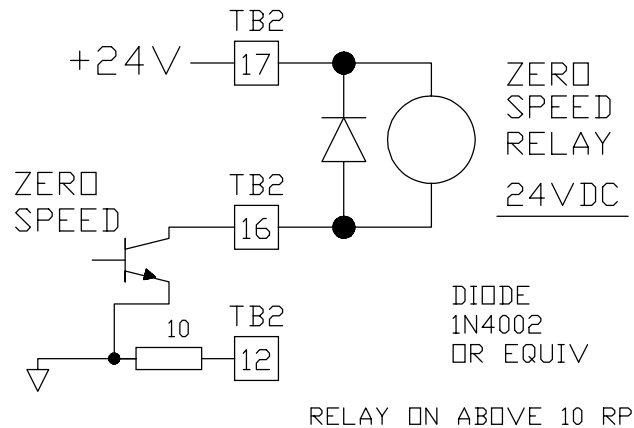

Figure 22: Connecting a ZERO SPEED relay. Note that the relay coil is 24VDC, so current should be kept low.

ZERO SPEED RELAY

A 24 VDC relay may be connected from the +24 VDC unswitched supply to the zero speed output terminal TB2 terminal 1 (see Figure 22).

The zero speed output is an open collector transistor with the collector connected to TB2 terminal 1 and the emitter to control common. The Zero Speed relay may be used to indicate that the motor is actually running.

The relay coil current must be limited to a maximum of 50 milliamps. The diode around the relay coil must be installed to prevent any high voltage transients at turn-off from

damaging the transistor or the power supply of the control. **DO NOT USE THE ZERO SPEED RELAY CONNECTION SHOWN IN FIGURE 22 WITHOUT CONNECTING THE DIODE AS SHOWN.**

The relay turns on when the motor is turning more than 10 RPM and stays on until the motor is no longer turning faster than 10 RPM. There is a small hysteresis built in.

The zero speed output is useful for determining if the motor is actually running. The pulses which control the zero speed output come directly from the motor. It is not necessary to use an external zero speed circuit to shut off the Model 4000. There is a built in RAMP STOP function. However, it is sometimes necessary to detect zero speed in a system.

On light loads at very low speed, the motor speed may change enough to cause the zero speed relay to “chatter”, especially with high gain or an incorrect STABILITY adjustment. This is caused by the rapid accumulation and discharge of pulses in the counting circuits which determine zero speed. Chatter does not affect the internal RAMP STOP function. The chatter is most likely to occur at low speeds and when things are happening quickly. As the load increases on the motor, the amount of chatter will be less.

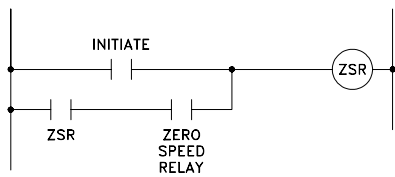

Figure 23: A circuit to eliminate chatter on the zero speed relay.

The chatter may be overcome by using the zero speed output to indirectly control an external relay which will perform the zero speed function, shutting off the first time the zero speed relay opens up and requiring some other signal

to turn on again. A typical circuit is shown in figure 23.

4.7 PLC INTERFACE

The interface of the Model 3500 with a process controller is dependent upon the ability of the PC to handle the required signals. Most of the signals are +24 VDC or +24 VDC and -24 VDC for control, or +10 VDC for speed. Computer

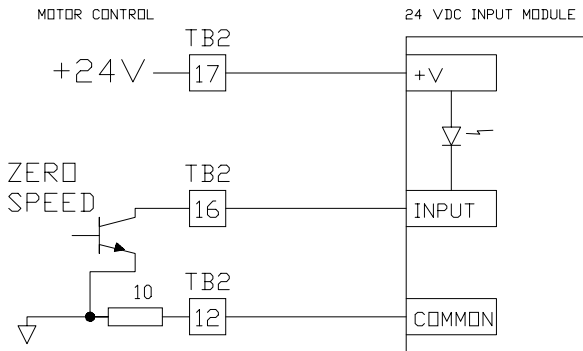

Figure 24: SINKING connection to a PLC.

generated frequency signals may also be used for speed (see section 4.5.2 and figures 16 and 17).

Figure 24 illustrates the method for using an open collector output to “sink” the input of a +24 VDC PC input module. There are two types of input modules. A “sourcing”

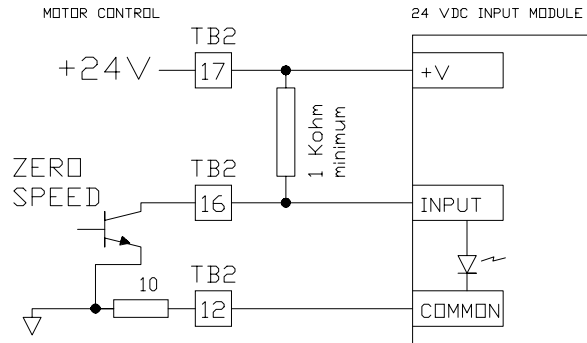

Figure 25: SOURCING connection to a PLC.

connection supplies voltage from the input source, but in the “sinking” connection, voltage supplied by the module and connected (sunk) to common by the connected input device. Figure 25 shows a sourcing connection.

Connections similar to those in figures 24 and 25 may be made to a PLC input module with the FAULT output of the control at TB1 terminals 12 and 13 to sense a FAULT in the drive. This is illustrated in figure 26. Remember that the FAULT output transistor is “ON” when there is no fault

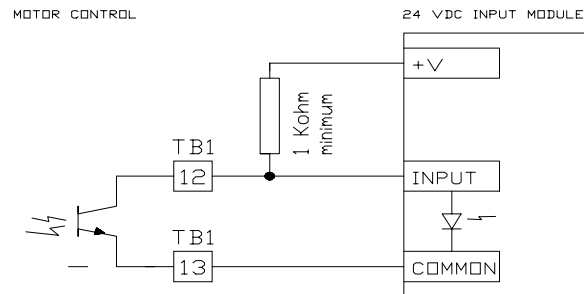

Figure 26: Connecting FAULT output to a PLC.

present in the control. This means a positive level at terminal 12 is a fault indication.

It is recommended that all operation of the control circuits of the Model 4000 be done with relays. These circuits see 24VDC to ground, but they operate at 48VDC. RUN, JOG, STOP and EMERGENCY STOP operate on +24 VDC supplies, but the circuitry is connected between positive and negative supplies, and it is difficult to make connections which do not involve both power supplies.

5.0 OPERATION

This section addresses the use of adjustments, option jumpers, and system setup to obtain the best performance from the **POWERTEC Model 4000** Brushless DC motor control for your application. After the physical and electrical installations are done, it is desirable to "tune" the control and motor to the process it is operating. There are some things which may be done with the motor and control and some things which may not be done. These things are what this section is about.

All customer adjustments and option jumpers are on the Speed Controller board (part number 141-107). There are option jumpers on some versions of the Current Controller board (part number 141-108), but these are used only for testing purposes. The Current Sensor board has calibration adjustments only. There are no adjustments on the Base Driver board (part number 151-049). The locations of all jumpers, adjustments, and test points are shown in the appropriate drawings in this section and the next section.

As pointed out in section 4, there are two distinct modes of operation of the **POWERTEC** Brushless DC motor control - Analog mode and Digital mode.

5.1 ANALOG INPUT OPERATION

The **POWERTEC** Brushless DC motor control is basically a digital type of control. The analog speed reference input capability is supplied for those who prefer to operate the control with a speed pot or from an external analog reference source. This input reference must be in the form of voltage. If a current based reference source is used, it must be converted to a voltage.

5.1.1 SPEED REFERENCE

In the analog mode, the speed of the motor is determined by a DC voltage reference applied to TB2 terminal 10 (with respect to TB2 terminal 12). A +10VDC reference source is available at TB2 terminal 9, referenced to drive common (TB2 terminal 12).

A reference voltage of +10 VDC will cause the motor to run in the "forward" direction at full speed (as determined by the MAX SPD pot setting - see section 5.1.4) if terminal 14 on TB2 (the Forward/Reverse input) is open. The motor may be reversed by applying +24VDC to terminal 14 (with respect to TB2 terminal 12, which is a drive common terminal).

Zero volts input at TB2 terminal 10 will produce zero speed. Be aware, however, that the Model 4000 will respond to inputs of more than 70 millivolts (0.07 volts), and the "zero volts" input must be less than this amount, or the motor will creep because of the offset.

The reference may come from any source capable of developing the required voltage. The input impedance at terminal 10 on TB2 with respect to TB2 terminal 12 is about 50 Kilohms for voltages up to +10.6 VDC. (Negative voltages will be clamped at -0.6VDC.) This high input impedance may cause the drive to respond to *electrical noise* present on the reference input. Shielded cable should be used for the reference input wiring. If long, exposed, wires are used from the reference source, it may be necessary to use a filter on the reference input to get rid of electrical noise.

If a 4 -> 20 mA current source is used, it must be converted to +10 VDC by either a fixed resistor (such as a 499 ohms, 1/2 watt, 1%) between TB2 terminal 10 and TB2 terminal 12 (if zero and span adjustments are not required for

the process), or by an optional Process Follower Board (Part #148-300 -- available at additional cost from **POWERTEC**).

The input DC voltage reference level may be changed at any rate desired and does not need to be removed while the Model 3500 is off. While the 3500 control is off, the input is held at zero by an input reference clamping circuit. This clamp is released as soon as a valid run command is given and the enable circuit is activated.

5.1.2 MINIMUM SPEED

There is a minimum speed potentiometer on the Speed Controller board (141-107) which may be used to establish a minimum reference voltage when the motor control's operator speed pot is turned to its minimum setting. This minimum reference voltage becomes a part of the full reference.

The value of the minimum speed potentiometer on the Speed Controller board is 1 Kilohm. With a 5 Kohm speed pot, the minimum speed may be adjusted from 0 to 15% of full

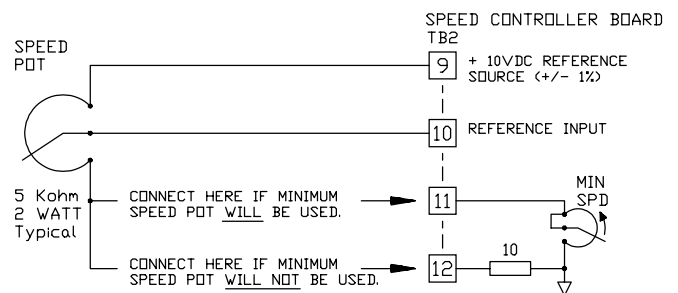

Figure 27: Connections for using or not using a minimum speed pot with the Model 4000.

speed. With a 10 Kilohm speed pot, the adjustment will be only 0 to 10 % of full speed.

This minimum speed pot is only be effective in the analog mode when a speed pot is used and the lower side of the speed pot is connected to terminal 11. It does not perform the minimum speed function when an external reference source is used or when the Model 4000 is used in the digital mode of operation. [A reference source for a speed pot (the high side) does not have to come from terminal 9.]

JUMPER POSITION	EFFECT OF PUTTING JUMPER IN THE INDICATED POSITION
OUT	ACCEL and DECEL rates are fixed at about 50mS from zero speed to full speed.
IN	ACCEL and DECEL rates are independently adjustable by the ACCEL and DECEL potentiometers from about 2 seconds to about 30 seconds.

5.1.3 ACCEL AND DECEL

The input reference command is held at zero internally while the control is off, and is released at the level present at TB2 terminal 10 to the ACCEL/DECEL circuit when the drive is started.

The ACCEL/DECEL circuit changes the reference rate of increase from a step, or near-step function to a fixed rate of increase or decrease which is adjustable by the ACCEL and DECEL pots. The rate will be affected by the Speed Controller board jumper labeled JP2. When jumper JP2 is installed, the control is in the RATE LIMITED mode. When jumper JP2 is NOT installed, the control is in the DIRECT mode.

In the RATE LIMITED mode, the ACCEL and DECEL pots may be used to set a desired rate of change of speed between 2 seconds and 30 seconds in standard units. If the desired ACCEL rate does not cause the motor to go to current limit, the change in speed will happen at a linear rate. If the required ACCEL rate is too fast for the available torque and load, the control will reach current limit, and that will modify the rate of change of speed.

Since the Model 4000 is not regenerative, the DECEL rate will only be effective if the coast time of the motor and load is shorter than the desired DECEL rate (see section 1.2 for an explanation of the terms).

The ACCEL and DECEL adjustments have very little effect in the DIRECT mode. This mode is used when speed changes must be very fast, such as with a rapidly changing input reference signal. However, BE AWARE that speed changes made in the DIRECT mode will be in current limit (for increasing speeds) or by coasting (for decreasing speeds)! When the drive is in current limit, the rate of change of motor speed is limited by the drive's output current limitation, not by a rate changing limit in the analog signal. If current limit is encountered in the response to input reference changes, the drive won't track large changes in the reference which approach step functions.

The ACCEL and DECEL potentiometers have no effect when the control is operated in the DIGITAL mode since the control is operating without using the VCO and the analog circuits are disconnected.

5.1.4 MAXIMUM SPEED

The analog circuits process the analog input signal for such functions as ACCEL and DECEL ramps, and JOG. The output of the analog reference circuits must then be converted to a frequency so that the digital circuitry of the Model 4000 may take over. This conversion is accomplished by a Voltage Controlled Oscillator (VCO), whose output in hertz is directly related to the voltage level at its input. This VCO is an infinitely variable circuit (as opposed to circuit which operates in 512, 1024, or 2048 steps).

The output frequency of the VCO must be calibrated to the input voltage of the VCO. This is usually set at the 10 VDC input level, but it may be done at other levels.

POWERTEC Brushless DC motors come with encoders which will produce a feedback rate of either 120 (4 pole motors) or 240 (eight pole motors - 280 frames and larger) pulses per revolution of the motor shaft. This requires that the VCO produce a frequency which is equal (in hertz) to two times or four times the RPM of the motor. For a 1750 RPM four pole motor, this works out to 3500 hertz (120 pulses/revolution X 1750 revolutions/minute X 1/60 minutes/second = 3500 pulses/second (hertz). For an eight pole motor, the pulse rate is 7000 Hertz for the same speed.

The calibration (maximum speed) adjustment for the applied analog reference may be accomplished with a hand held tachometer. During start-up, when the time comes to set the maximum speed (preferably after the motor has reached operating temperature), the calibration is made by adjusting the MAX SPD potentiometer for the nameplate RPM rating while the speed pot is set for +10VDC at TB2 terminal 10, measured with respect to TB2 terminal 12. The MAX SPD pot is adjustable from about 2000 to about 10000 hertz (with a +10 VDC input reference). This corresponds to about 1000 to 5000 RPM on the standard two pole motor and about 500 to 2500 RPM on the standard eight pole motor. (Eight pole brushless DC motors are generally those with frames 280 or larger).

If the MAX SPD pot is set too low, the motor will not run up to its rated speed, although it will continue to increase its speed over the entire range of the operator speed pot adjustment from 0% to 100%. If this is the case, then the MAX SPD pot may be turned clockwise until the motor is running at rated speed.

NOTE: If the motor is cold, and the motor is heavily loaded, the motor may not come all the way up to rated speed. This will be indicated by the CURRENT LIMIT light coming on, though there is no appreciable amount of load and large amounts of current are not being drawn. The motor is not running up to rated speed, although the MAX SPD pot is turned beyond the point where speed has stopped increasing. If this happens, allow the motor to run for a while before making the MAX SPD setting.

If the MAX SPD is set too high, the motor will stop increasing in speed before the operator speed pot reaches its full range (100% clockwise). In this case the CURRENT LIMIT light will come on, though little current is being used, and the speed will be erratic. Turn the MAX SPD pot counter-clockwise until the CURRENT LIMIT light goes out (even if this is below base speed) to attain speed control, and then set the MAX SPD pot (see the cold motor note above).

Remember that this Model 4000 maximum speed adjustment is in reality just a calibration to the input reference of 10 VDC. **It is not an absolute speed limit.** If more than 10 VDC is applied to the reference input, the motor will go faster (the input circuits clamp the input reference at +10.6 VDC and negative voltages to -0.6VDC).

DO NOT ATTEMPT TO MAKE A MOTOR RUN AT ANY SPEED GREATER THAN ITS BASE SPEED UNLESS THE MOTOR WAS PURCHASED FOR HIGH SPEED OPERATION FROM THE FACTORY.

5.1.5 RAMPSTOP

The RAMP STOP jumper, when installed, maintains the control in the enable condition after a stop command is given (+24VDC is removed from TB2 terminal 5 by the ramp stop button, or from TB2 terminal 4 when a switch or contact is used). The input speed reference is clamped to zero. This will decelerate the motor to zero speed (the motor will coast to rest if the coast time is greater than the DECEL time), and, when the motor gets below about 10 RPM, the control will shut off and after that it must be re-started with a RUN command to TB2 terminal 4.

If the RAMP stop jumper is not installed, a ramp stop shuts off the control and the motor will coast to a stop.

RAMP STOP JUMPER TABLE	
ANALOG MODE	
IN	Upon the RAMP STOP command, the motor decelerates to zero speed at the DECEL rate, or coasts to stop if coast time is longer than DECEL time, then the control shuts off.
OUT	Control shuts off immediately upon a RAMP STOP command. The motor will coast to a stop.
DIGITAL MODE	
IN	The input frequency must be reduced to zero when the RAMP STOP command is given; the motor coasts to a stop if the frequency is reduced faster than the coast time of the motor and load, then the control shuts off.
OUT	Control shuts off immediately upon a RAMP STOP command. The motor will coast to a stop.

5.1.6 JOGFUNCTION

The POWERTEC Model 4000 has a built-in JOG function which may be used to turn the motor, usually for short periods of time, without using the RUN function.

The JOG function does not seal in and hold itself on as does the RUN function. JOG will accelerate the motor very rapidly when +24 VDC is applied to TB2 terminal 13 and then decelerate the motor very rapidly to zero speed when the voltage at terminal 13 is removed (the +24 VDC should come from a point after the Emergency Stop button). See section 4.4 and Table 1 on page 17).

Speed is determined, in the analog mode, by the setting of the on-board JOG potentiometer, which is adjustable from zero to about 15% of the MAX SPEED setting. (Speed in the digital mode is determined by an external frequency which is applied while the JOG function is active.)

There is no ACCEL or DECEL ramp in the analog JOG mode. The JOG reference will produce the JOG speed output as a step function, where the acceleration or deceleration of the motor will be limited only by CURRENT LIMIT.

If a jog function with ACCEL and DECEL is desired, it is better to use a non-latching RUN function for jog. This may be accomplished by opening up the connection to the RUN holding terminal TB2 terminal 5 and applying a RUN command to the RUN terminal at TB2 terminal 4. As long as TB2 terminal 5 is open, the drive will RUN only as long as contact closure on TB2 terminal 4 is maintained. When that contact is opened, the control will ramp stop the motor, if the ramp stop jumper is installed. Speed in this mode will not come from the JOG pot, but from the reference input at TB2 terminal 10.

The JOG function is NOT locked out during the RUN function. If the JOG function is energized while the RUN function is active, the JOG function will override the RUN.

5.1.7 BI-DIRECTIONAL JOG

The capability for jogging in either direction in a system must be installed. It is not built into the system. This requires simultaneous application of a directional signal (+24 VDC at TB2 terminal 14) and a speed signal (from the JOG pot in ANALOG mode, or a frequency representing JOG speed in DIGITAL mode).

In ANALOG mode, the direction of the motor in JOG is determined by the presence or absence of +24 VDC at TB2 terminal 14. With the FWD/REV terminal 14 at 0 VDC (or if the terminal is open), forward JOG will result if the JOG input (TB2 terminal 13) is activated. Activating the JOG with +24VDC applied at terminal 14 will result in a reverse JOG. Speed command in JOG comes from the JOG pot.

Bi-directional JOG may be accomplished in the same way in the DIGITAL mode, but if the control remains in the DIGITAL mode during the JOG function, a frequency for the JOG speed must be supplied at TB1 terminal 11, with respect to TB1 terminal 9, which is NOT the drive common. TB1 terminal 10, which is the input for the DIGITAL mode, is also referenced to terminal 9. Terminals 9, 10 and 11 on TB1 are an isolated circuit. See figure 16, section 4.5.2.

5.2 DIGITAL MODE

When +24 VDC is applied to TB1 terminal 10 with respect to TB1 terminal 9, the Model 4000 or is switched into the **DIGITAL MODE**. This means that the speed of the drive will no longer be dictated by the input reference at TB2 terminal 10, nor will it respond to the ACCEL and DECEL pots, or to the JOG function. MAX SPEED will have no effect on speed and the position of the JP2 jumper will have no meaning in DIGITAL mode.

The control will now respond to a properly applied signal at TB1 terminal 11 with respect to TB1 terminal 9 (see section 4.5). For four pole motors, this will be a square wave frequency of 2 times the motor RPM desired in hertz (1750 RPM = 3500 Hertz). Eight pole motors require a frequency of 4 times the motor RPM (1750 RPM = 7000 Hertz). The reference to frequency is only for the sake of convenience in describing the input waveform. The motor control will respond *pulse for pulse* to this input.

The standard eight pole motor, after processing by the pulse circuits, produces 240 feedback pulses for each revolution of the motor. Each reference pulse applied at TB1 terminal 11 causes the motor to turn 1.5 degrees. This will apply whether the motor is at or near zero speed, or if it is turning at or near base speed. There isn't any acceleration or deceleration rate associated with these pulses. They are applied and responded to immediately.

Each pulse of reference increases the amount of torque available to the motor (accelerates the motor) and each motor feedback pulse decreases the amount of torque available to the motor (decelerates the motor). For any given load and speed, the amount of torque required to run the load will cause a number of pulses to be accumulated which is proportional to the amount of torque required to run the load.

Once the amount of torque required to run the load is developed, every pulse of reference *must be answered* by a pulse of feedback from the motor or the control accumulates enough pulses to go into current limit. The only times that pulses will be lost is if the 4000 goes into current limit, or if a rapid decrease in the pulses rate cannot be responded to because of high inertia. The Model 4000 is not regenerative and cannot brake the motor to match a rapidly decreasing pulse train. If the drive does not go into current limit and the load is such that the motor can slow down as fast as the pulse rate, then each pulse turns the motor 3 degrees. With eight pole motors, each pulse results in 1-1/2 degrees of rotation .

A GAIN potentiometer determines how many pulses will be accumulated to reach current limit. At the minimum setting of the GAIN pot (full counter-clockwise), about 90 pulses will be needed to reach current limit. At the maximum setting (clockwise), only about 10 pulses will accumulate before current limit is reached. Since each pulse represents 3 degrees of a motor revolution, the motor cannot be off more than 270 degrees from where it should be before current limit is reached. If 1750 RPM is being commanded, the motor must

run at exactly 1750 RPM, and can't lose even a single revolution, even over a period of time, regardless of load short of current limit. This means the speed regulation is zero percent (no loss of speed from no load to full load).

The frequency may be ramped from zero to the desired speed, or ramped from one speed to another, to avoid current limit. If losing pulses during acceleration or deceleration is not a concern, the input frequency may be applied all at once, or even left running into the input while the control is off. The motor must run at the commanded speed, or be in current limit.

In DIGITAL mode, a RAMP STOP command will decelerate the motor to zero speed and shut off **ONLY IF** the RAMP STOP jumper JP1 is installed and the frequency at TB1 terminals 11 and 9 (see section 4.5) is reduced to zero when the ramp stop is initiated. If the frequency is not reduced to zero, the motor will continue to run at the speed dictated by the frequency until some other action is taken (such as EMERGENCY STOP). **DO NOT USE RAMP STOP IN DIGITAL MODE UNLESS EMERGENCY STOP IS CONNECTED TO A PUSHBUTTON OR EMERGENCY STOP SYSTEM!**

The JOG function may be simulated in DIGITAL mode by applying a string of some number of pulses to the frequency input, then cutting off the string of pulses. It is also possible to interrupt the TB1 terminal 10 connection during the JOG function to allow use of the analog JOG mode.

THERE IS NO MAXIMUM SPEED PROTECTION WHILE OPERATING IN THE DIGITAL MODE.

IT IS THE RESPONSIBILITY OF THE USER TO MAKE SURE THAT THE SPEED COMMANDED DOES NOT EXCEED THE MOTOR'S MAXIMUM SAFE SPEED WHILE OPERATING IN THE DIGITAL MODE!!

5.3 CURRENT LIMIT

CURRENT LIMIT is the maximum amount of output current which the drive will be allowed to give when it is powering the load, i.e., power is being drawn by the motor to perform work. The current limit is a peak-detecting circuit which will limit the current drawn on every PWM pulse. The amount of current allowed is determined by the motor rating, allowing no more than 150% of nameplate current.

The current limit and the TRIP levels are calibrated for each individual control by a Horsepower calibration Resistor on Terminals 1 and 3 of TB3 on the Capacitor Board (part # 141-106). Horsepower Calibration resistor values are listed in section 2.1 on page 9 of this manual. Those values are calculated values which will be close to the best value for that size unit. The Trip and Horsepower calibration resistor values may vary for the various sizes for the following reasons:

It is the nature of brushless DC motors that the amount of current drawn by any given Horsepower and Voltage rating

will vary somewhat with the RPM's of the motor. For this reason, the Horsepower calibration resistors of units shipped from the factory may vary from unit to unit.

The hall effect sensors on the Capacitor Board may vary, not so much from unit to unit, as from batch to batch.

Each motor control is calibrated at the factory and its calibration resistor is installed under actual load test.

Trip and current feedback calibration adjustments on the Capacitor Board are also set at the factory.

DO NOT CHANGE THE VALUE OF THE HORSE-POWER CALIBRATION RESISTOR WITHOUT CONSULTING THE FACTORY. THERE ARE MANY FACTORS INVOLVED IN THE CHOICE OF THE CALIBRATION RESISTOR.

The current limit potentiometer may be adjusted anywhere from 0% to 100% of its rotation. When the pot is at 0% (full CCW), the current limit is 0%. Full clockwise rotation gives 150% current. The pot may be set anywhere in its rotation. The current setting is linear through the rotation (i.e., 50% rotation is about 75% of full load current).

Current limit in the motoring mode will result in the motor finding a speed (which may be zero) at which it can maintain the load at the current level allowed by the current limit. It will continue to find whatever speed it can maintain as long as it is in current limit, and that speed may vary.

When current limit is reached, it means that the control is putting out all of the current allowed. If current limit is reached frequently, other than during periods of rapid acceleration, the motor and/or the control size should be increased.

DO NOT ATTEMPT TO SOLVE THIS PROBLEM BY CHANGING THE CALIBRATION RESISTOR. THIS MAY CAUSE DAMAGE TO THE MOTOR AND/OR THE CONTROL.

A condition which gives a "current limit" indication, but is not current limit, occurs when the motor is running as fast as its counter-EMF (CEMF is the voltage generated by the motor) will allow. This condition normally occurs with no load or a light load, and, most of the time, when the motor is cold. As the speed command increases, the motor will not speed up any more and the current limit light comes on, though little current is being drawn.

This condition is referred to as "running against the buss" because the motor speed is being limited by the available buss voltage. A cold motor may do this below base speed, because a cold motor produces more CEMF (and more torque per amp also). After a cold motor warms up, its speed will increase.

If a warmed up motor appears to be up against the buss, turn down the MAX SPEED until the current limit light goes out and recheck the speed.

5.4 GAIN AND STABILITY

A certain level of current must be drawn from the control by the motor to develop the torque required to turn the load at any given speed. The **POWERTEC** Brushless DC motor control works on the basis of balancing the number of reference pulses against the number of feedback pulses from the motor. The output current from the control is directly proportional to the number of pulses in an up/down counter which accumulates the difference between the number of reference and feedback pulses. This difference is between the NUMBER of pulses, NOT the frequency of the pulse train. The counter will accumulate pulses until it has developed the current which the motor is demanding to satisfy the speed loop. The accumulated pulses will remain in the counter until the load changes. Each feedback pulse from the motor represents 3 degrees of shaft rotation on a four pole motor.

Once the pulses necessary to develop the current are accumulated, each one of the reference pulses must be answered by a feedback pulse from the motor. If the load is decreased, the torque required is decreased, and the drive responds by shedding some of the accumulated pulses.

Increasing the GAIN pot reduces the number of pulses needed to reach the required current level. This shows up as a more responsive control since the effect of each pulse is more pronounced. When the GAIN pot is set fully CCW, the number of pulses needed to reach current limit is about 90. Each pulse accumulated will increase the current output of the control by 1/60th of the full load current level. If the GAIN pot is turned fully clockwise, only about 10 pulses will have to accumulate before the control reaches current limit. Then each pulse will increase the current output of the drive by 1/10th of the current limit level. Only six or seven pulses will be required to reach full load.

While this may seem desirable from the standpoint of having a tight control, it produces a lot of "jitter" in the motor shaft at low speeds, particularly on unloaded or lightly loaded motors. The large change in current level causes the motor to "overshoot" (it only has to go a few degrees to "overshoot"). This overshoot causes the counter to count down to zero. Then it has to wait for more reference pulses before it can accumulate enough pulses to put out current again.

Experience has shown that in single motor applications a setting of about 50% on the GAIN pot gives good results in ANALOG mode. In DIGITAL mode higher settings may be needed so that the input pulses may be more closely tracked.

The STABILITY adjustment is a dynamic adjustment. In general, as the GAIN adjustment is turned higher, the STABILITY adjustment must be increased. Lower settings of the STABILITY will produce a jittery operation while higher (CW) adjustments will produce sluggish operation.

The STABILITY adjustment has a 20:1 dynamic range. Since different motor loads have different values of friction, inertia, and cyclic properties, there is no procedure to set STABILITY. The best advice is to start at 50% of the pot rotation and adjust for best results.

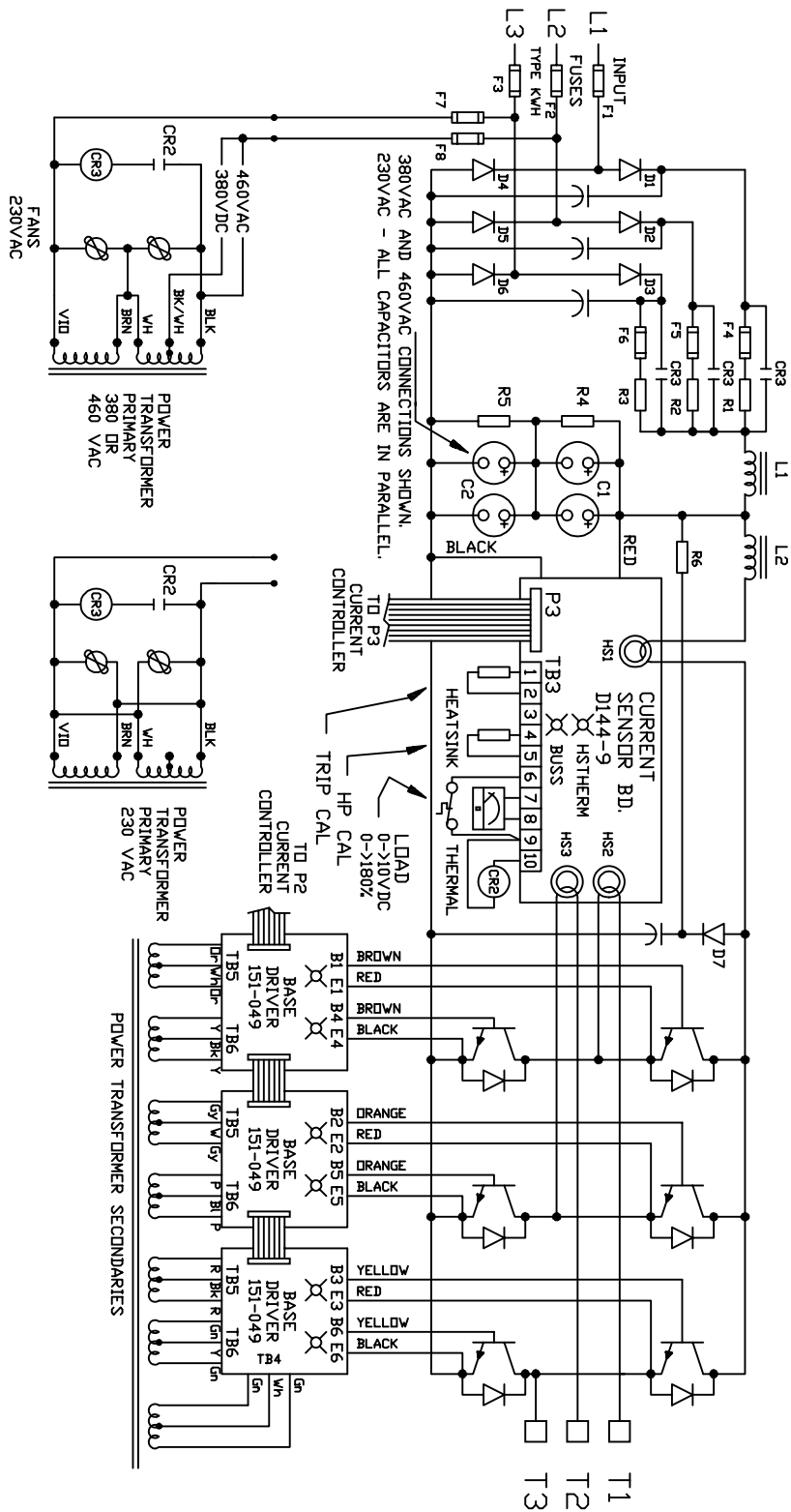

Figure 28: Simplified schematic drawing of the Model 4000 power circuits.

6.0 THEORY AND TROUBLESHOOTING

Figure 28 is a somewhat simplified schematic diagram of the power section of the **POWERTEC Model 4000** Brushless DC motor control. The circuitry is the same as other **POWERTEC** non-regenerative controls. The only differences are in the size and power handling capability of the components.

The high power section is electrically isolated from the control electronics. The only connections between the power section and control section are two ribbon cables.

6.1 INPUT POWER SECTION

The main power is connected to the input fuses. The line power is 3 phase AC power of 230, 380, or 460 VAC. **CHECK THE CONTROL NAMEPLATE FOR THE PROPER INPUT VOLTAGE BEFORE APPLYING POWER!**

Section 2.1 lists the input power requirements. This power must be within specified conditions (section 2.3) at all times. Line frequencies from 48 to 62 Hertz are acceptable.

See figure 14 on page 15.

The input fuses are a fast-acting type of fuse which is chosen for its very high interrupting capacity (200,000 Amperes Interrupting Capacity) for ground and short circuit faults within or after the control input.

DO NOT SUBSTITUTE ANOTHER TYPE OF FUSE FOR THE INPUT FUSES! Use only FWH type fuses or an equivalently rated fuse.

When the input power is applied, diodes D1 through D6, which may be contained in several molded blocks, rectify the A.C. power at the input into D.C. power for the power buss. The size and type of diode bridge will vary according to the voltage and horsepower rating of the control.

Power for the low voltage transformer is tapped off after the main fuses. The transformer, protected by F7 and F8, is a multi-tap type which is connectible for 230, 380 and 460 VAC. All the secondaries of the power transformer connect to the Driver Board 151-049.

6.2 CHARGINGSECTION

Contactors CR3 is open when power is applied, and therefore capacitor banks C1 and C2 (there may be up to 10 paralleled capacitors in each bank) charge up through resistors R1, R2, and R3, which are located on the chassis along with protective fuses F4, F5, and F6. The fuse prevents the resistor from burning up when trying to charge a buss which won't charge for any reason.

The capacitor banks C1 and C2 may be connected in series or in parallel. They are connected in parallel for 230VAC input units. When the unit is connected for 380VAC or 460VAC, voltage divider resistors R4 and R5 ensure that the voltage is equally divided across the 380VAC (530VDC) or 460VAC (640VDC) buss capacitor bank.

The buss will charge up to about 90% of the nominal value through the resistors in about 10 to 15 seconds, depend-

ing on the voltage connection and the number of capacitors. When the charging currents through the resistors drop below a certain point, contactor CR3 will close and the capacitors will finish charging through inductor L1.

L1 limits the rate of change of current while the control is in operation. It also prevents the peak currents drawn from the power line from getting too high, thereby improving the RMS current value and resulting in a better power factor on the supply system. L1 also reduces the effects of noise, both incoming to the control and out-going to the lines.

NOTE: These and following problems are only possible problems - things that MAY happen due to the electrical construction of the motor controls. They do not represent a history of problems encountered.

POSSIBLE PROBLEM:

INPUT FUSES BLOW WHEN POWER IS APPLIED.

1. With power off, see if the charging contactor CR3 on the chassis is stuck closed. Use an ohmmeter.
2. With an ohmmeter, check the diodes D1 through D6 by checking each line to the positive and negative terminals.
3. Watch the BUSS CHARGED LED on the current controller board to see if it comes on immediately when power is applied.
4. Check for grounded buss or motor connections.

POSSIBLE PROBLEM:

FUSES BLOW WHEN CR3 ENERGIZES.

1. Connect a voltmeter across the positive buss (+) bar and the negative buss (-) bar on the Capacitor Board, and watch the rate of charge to see if CR3 is pulling in prematurely. CR3 should pull in at about 90% of nominal buss.
2. With power off (MAKE SURE THE CAPACITORS ARE DISCHARGED), use an ohmmeter to determine if there is a short across the buss.
3. If the BUSS LED (on the Current Controller 141-108) stays red for more than 30 seconds, shut off power and connect a voltmeter from the positive buss connection to the negative buss connection on the Capacitor Board. Reapply power and check voltage. The voltage across the capacitors should be nearly equal. If not, there may be a bad capacitor, or a voltage balancing resistor (R4 or R5) may be open.

POSSIBLE PROBLEM:

CONTROL DOES NOT POWER UP.

1. If no LED's are lit on boards, check the input fuses.
2. If no LED's are lit on the PC boards, check fuses F7 and F8.
3. If BUSS LED stays red more than 30 seconds, check fuses F4, F5, and F6.

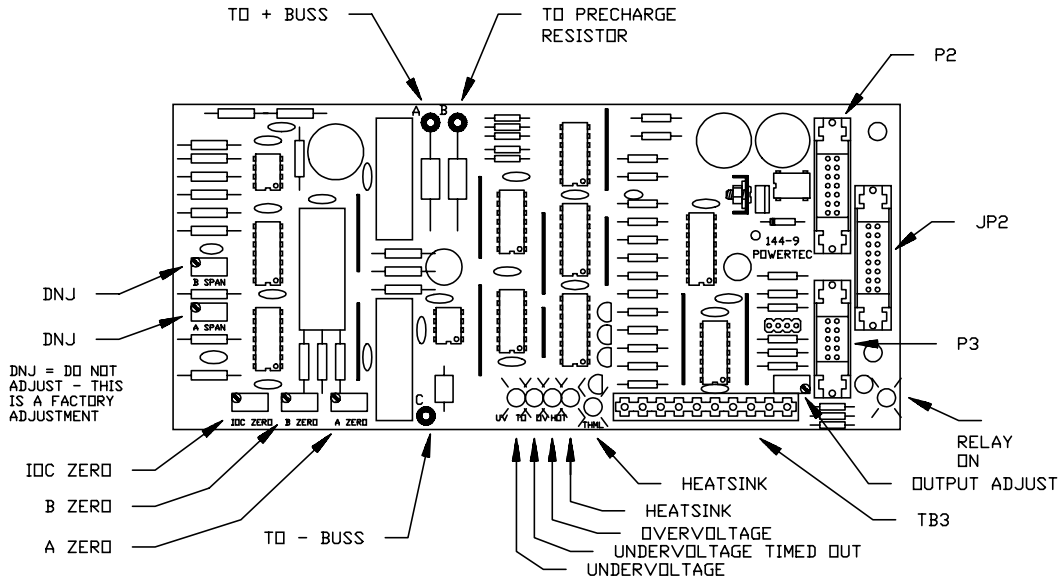

Figure 29: Parts layout and important points on the Current Sensor board 144-9.

6.3 CURRENT SENSOR BOARD

The Current Sensor Board (part # 144-9) contains circuits which monitor the voltage across the capacitors:

1. When power is turned on, the Current Sensor Board monitors the increase in voltage across the capacitors and closes CR3 when the current through the charging resistor drops below 10% of the beginning charging current. It will maintain CR3 in an energized state until the voltage across the buss drops below 80% of nominal buss. An LED near P3 indicates when the relay is energized. An LED labeled BUSS CHARGED on the Current Controller board (141-108) changes from red to green when the contactor is energized.

2. After power up, the Current Sensor Board monitors the buss voltage. If the input power goes away or if the buss falls to 85% of nominal (even for a short time), the transistors are turned off and a timer begins timing. If at the end of 80mS, the power has not returned, the drive trips. If the timer trips, or if buss voltage drops below 80%, or if the buss voltage rises more than 120% of nominal, an OV/UV indication will be sent to the Current Controller. An OV/UV will be also be sent to the Current Controller if an input power phase is lost.

The Current Sensor Board has three "hall effect" current sensors mounted on it. They monitor flux around two of the motor lead wires for current limit sensing, and in the wire between the positive side of the capacitor bank and the collectors of the transistors connected to the positive side of the buss, which is carrying buss current.

ALL ADJUSTMENTS ON THE CURRENT SENSOR BOARD ARE FACTORY ADJUSTMENTS EXCEPT THE OUTPUT ADJUSTMENT (P6)!

The buss current sensor is calibrated by the Trip Calibrate resistor (located on TB3 terminals 1 and 2). This resistor is installed by the factory using accurate instruments and methods for a trip at 300% (instantaneous) of the buss full load current. See section 2.1 (page 9) for approximate value.

The HORSEPOWER CALIBRATION resistor (terminals 4 and 5) may vary between units shipped from the factory because load currents in motors of the same HP, but at different base speeds, or different enclosure types, etc, may be at different levels. Section 2.1 (page 9) gives nominal values.

The Current Sensor Board develops its own power supplies (raw supplies come from the power transformer).

POSSIBLE PROBLEM:

CR3 DOES NOT ENERGIZE.

1. Check the BUSS LED on the Current Controller Board. If it is on, check CR3 coil for +24VDC. If the coil voltage is missing change the Current Sensor Board. Otherwise, change CR3.

POSSIBLE PROBLEM:

IOC OR OV/UV LED ON THE CURRENT CONTROLLER BOARD COMES ON WHEN BUSS LED TURNS GREEN AT POWER UP.

1. Check to see if the HP CAL resistor has been installed on TB3. If not, check section 2-1 for proper value.
2. Check the voltage across C1 (+ side) and C2 (- side). Check against the following table:

Nominal AC input voltage	Buss Voltage too low less than	Buss Voltage too high more than
230	270	390
380	450	650
460	550	780

3. Make sure all three phases are present at the input fuses.

6.4 POWER OUTPUT SECTION

The output transistors are turned on and off (no more than two on at the same time) to supply current to the brushless motor as determined by the speed and load regulation circuitry on the Speed and Current Controller boards. Control power for the output transistors come from the base driver boards (see figure 28). The output transistors are protected by snubber elements to suppress high spikes and transients caused by switching high voltages on an inductive load at high frequencies (up to 1.8 Kilohertz). "Free wheeling diodes" built into the transistor packages carry circulating currents which occur when the transistors are off.

It is very important that the terminals T1, T2, and T3 be connected to T1, T2, and T3 respectively on the motor. The other connections at the motor end will vary with the speed, horsepower, and voltage of the motor.

The three base driver boards (part # 151-049) are switched on and off by the Current Controller Board through the P2 cable. The boards each serve two transistors. An LED indicates that an output transistor is turned on. These lights may be difficult to see when the motor is lightly loaded due to the Pulse Width Modulation. The length of time that the transistors are on is proportional to load on the motor.

The base driver boards are each supplied by two windings on the transformer, one winding for the A driver, and one winding for the B driver. The base driver board supplies raw power supplies (+24VDC and -24VDC to common) to the other PC boards, so one of the boards gets an extra winding connection (the green-green/yellow-green winding) on its P1 connector. It does not matter which one gets the connection.

The base and emitter wires going from the Base Driver boards are color coded to prevent mix-ups (figure 30). **IT IS VITALLY IMPORTANT THAT THESE WIRES NOT GET MIXED UP.** Connecting the wrong wires to the wrong transistors on the output **WILL DAMAGE THE CONTROL!**

POSSIBLE PROBLEM: MOTOR DOES NOT TURN.

1. Check to be sure T1, T2 and T3 are connected properly.
2. Make sure motor cable is properly connected.
3. Check for ENABLE light on Current Controller board.
4. Check to see if any Base Driver Board LED's are lit.
5. Check for trip on Current Controller Board.

POSSIBLE PROBLEM: INPUT FUSES BLOW WHEN THE RUN OR JOG CIRCUIT IS ACTIVATED.

1. With power off (wait for the capacitors to discharge), disconnect motor leads at T1, T2, and T3.
2. With an ohmmeter (preferably with a diode scale) check for a shorted transistor in the output bridge.
3. If no shorted transistor is found, power up with the motor leads T1, T2, and T3 disconnected. Turn speed pot to about 10%. If the fuses do not blow when run is commanded, check the wiring to the motor for grounds or shorts..

POSSIBLE PROBLEM: CURRENT LIMIT OR TRIP ON START OR JOG.

1. Make sure the shaft of the motor is free to turn.
2. Uncouple the motor from the load, and try to operate the motor.
3. Check motor connections, both power and cable.
4. Make sure that the HORSEPOWER CALIBRATION resistor is installed on Capacitor Board.

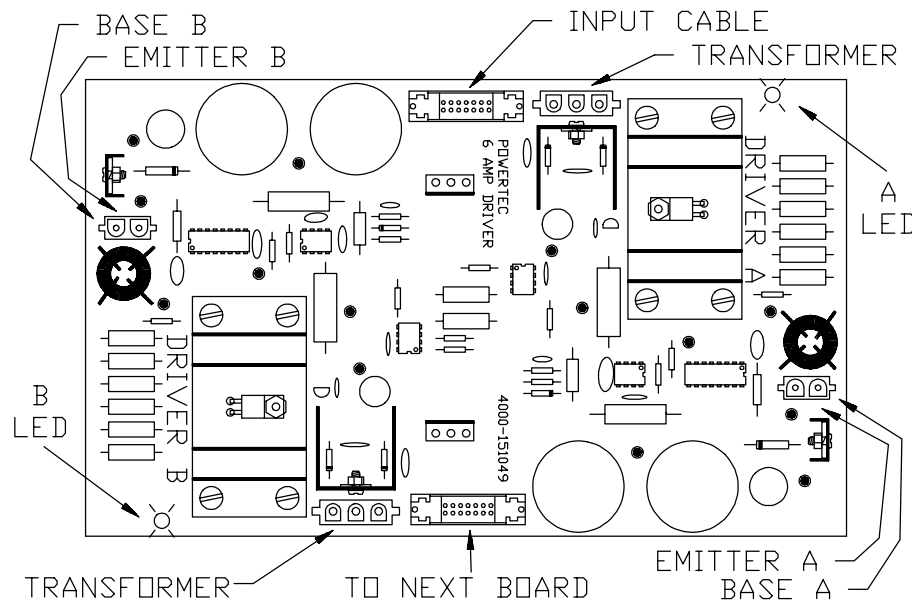

Figure 30: Layout and connections of the Base Driver Board 151-049.

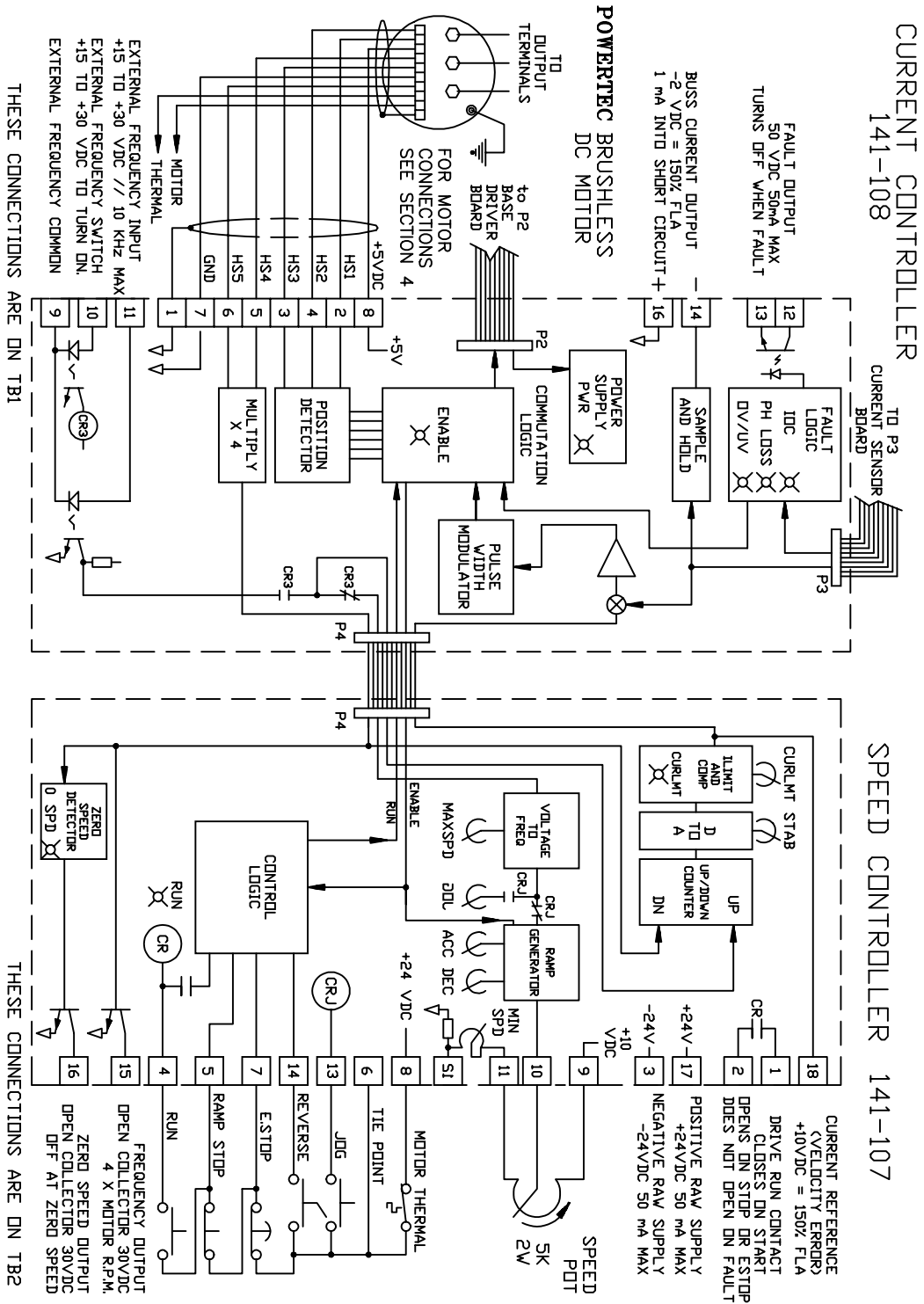

Figure 31: Block diagram of the Model 4000 CURRENT CONTROLLER and SPEED CONTROLLER BOARDS.

6.5 CURRENT CONTROLLER 141-108

Refer to the BLOCK DIAGRAM in figure 31.

The Current Controller Board (part #141-108) contains the main operational and protective logic of the **POWERTEC** brushless DC motor control. It develops low level power supplies (+24VDC and -24VDC) from AC power supplied through the cable connected to the base driver board and develops its own regulated supplies (+15VDC, -15VDC, and +5VDC). The Current Controller has the following functions:

1. It will lock out the drive on a fault if it receives a signal from the capacitor board (Over or Under Voltage or OverCurrent), from the base driver board (Power Loss), or from its own fault monitor. When in the fault mode it turns off an optical coupler which communicates with the outside world (TB1 terminals 12 and 13). This coupler is normally turned on. STOP is NOT a fault mode.

A fault is reset when the run command at TB2 terminal 4 is removed if the RESET SELECTOR (see figure 32 below) is in the INT position (the left two pins of the jumper). If the jumper is on the right two pins (the MAN position), the control will not reset a fault unless the input power is turned off and then on again, or the jumper is moved to the middle two pins momentarily (there should not be a RUN command present when this is done!) and then placed on either the left two pins (internal reset) or the right two pins (manual reset). The control will not run with the jumper on the middle pins.

2. It determines if an outside frequency is called for (+24VDC between TB1 terminals 10(+) and 9(-)), and substitutes the frequency at TB1 terminals 11(+) and 9(-) for the internal VCO frequency.

3. It will accept a run enable request from the Speed controller board, and, if there is no fault, it will return an ENABLE signal. The enable request is interlocked through a connection on the Current Sensor board.

4. It compares a current reference command (velocity error) from the Speed Controller board against the current signal received from the Current Sensor Board. If the actual current is greater than the amount of current allowed, the current output is limited by adjusting the pulse-width modulation. Current limit is checked every PWM pulse.

5. It takes a sample of the current in a sample and hold circuit, where it may be monitored by external means between TB1 terminals 14(-) and 16(common). The current level is calibrated by the Horsepower Calibration resistor on the Current Sensor board (-2VDC = 150% of full load current).

6. It receives the encoder signals from the encoder on the motor. There are five channels. Three of the channels are used to determine shaft position (HS1, HS2, and HS3). The Current Controller board generates the complementary signals and feeds all six signals to the EPROM in the L3 socket (a 141-300 is standard). The position channels of the encoder are used by the Current Controller to determine the output transistor firing sequence. There are three lights on the Current

Controller board which monitor the position encoder channels (labelled HS1, HS2, and HS3).

The other two channels (HS4 and HS5) are used to regulate speed and to determine direction of rotation of the motor. The signals from HS4 and HS5 have the same pulse rate, but they are in "quadrature" (90° out of phase). The Current Controller board detects the leading and trailing edges of each of the speed signals and combines them to allow the EPROM to select a X4, X2, or X1 feedback rate. The standard EPROM (141-300) multiplies the single channel pulse rate by four (X4). For a four-pole motor (140, 180, 210, and 250 frames), the sixty pole encoder wheel supplies a 30 PPR feedback rate in each of the HS4 and HS5 channels. The standard EPROM multiplies this by four to supply a 120PPR feedback rate to the Speed Controller board. Other EPROMs may supply other feedback rates.

7. The Current Controller board gives the signals to the base driver boards to turn the output transistors on and off, as determined by the position encoder signals, by the direction of rotation commanded, and controls the PWM frequency according to the motor conditions.

POSSIBLE PROBLEM:

ENCODER LIGHT OR LIGHTS NOT CHANGING.

1. Check the power supply at TB1 terminals 8(+) and 7(-). It should be 5.0VDC +/- 0.1VDC.

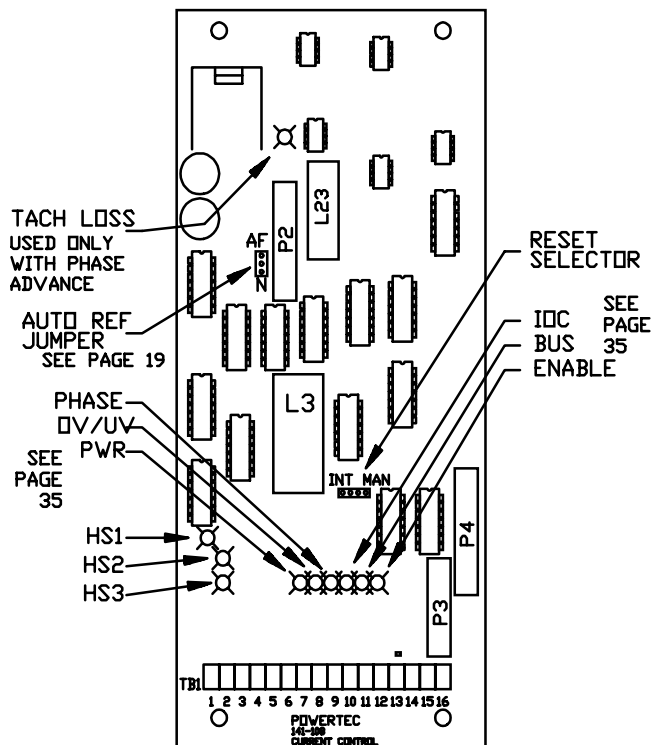

Figure 32: Major parts of the 141-108 Current Controller board.

2. Check the signals at TB1 terminals 2, 3, and 4. The proper signals are illustrated on page 8 of the Motor manual.
3. Change the Current Controller Board.

6.6 SPEED CONTROLLER 141-107

The Speed Controller Board (part #141-107) handles the speed control of the control. It also takes care of the start, stop, jog, emergency stop, and reverse control logic functions of the Brushless DC motor control.

CONTROL LOGIC FUNCTIONS -- The Speed Controller supplies +24VDC (terminal 8 on TB2) to the operator devices and accepts signals for Emergency Stop (immediate coast stop) on terminal 7 on TB2, ramp stop (decelerate to zero speed before shutting off - E.Stop must remain energized during the ramp stop period) on TB2 terminal 5, and RUN (momentary with holding contact, or two-wire) on TB2 terminal 4. A jog function is entered on TB2 terminal 13, but be aware that the Jog function will override the RUN function if it is activated while the RUN is active.

The direction of rotation of the motor when operating in either digital or analog input mode is determined by the presence of +24VDC at the reversing terminal. If +24VDC is not applied to TB2 terminal 14, the motor will operate in the "forward" direction. Applying +24VDC at TB2 terminal 14 will cause the motor to decelerate to zero speed (if it is not already there), electronically reverse the motor at zero speed, and then accelerate the motor at the ACCEL rate to the speed set at the speed pot.

If the control is operating in the digital mode, the frequency input must be reduced to zero when the reverse command is applied, then the frequency can be reapplied once the motor comes to a stop.

SPEED REGULATOR FUNCTION -- All customer adjustments are located on the Speed Controller board. There are also jumpers to range the ACCEL and DECEL times and to set up the RAMP STOP function.

The speed command is ramped to and from changing setpoints by the ACC/DEC circuit (removing the JP2 jumper shortens the time to about 50 milliseconds full scale). The output of the ACC/DEC circuit is fed to a voltage-controlled oscillator (VCO) which is linear within 0.5% over the speed range. The VCO frequency is routed through the Current Controller in case an external frequency is desired.

The reference frequency is routed to the up/down counter as "count up" pulses. The pulses from the speed encoder (Current Controller Board) is routed to the up/down counter as "count down" pulses. A register holds the accumulated number of error pulses, which is converted into an error voltage to be used as a current reference by the Current Controller. The number of pulses accumulated is directly proportional to the output current of the control.

Under all normal operating conditions (which excludes current limit), the number of pulses received from the speed reference must be balanced by the feedback pulses from the motor. In the standard control, the pulse rate from the motor will be 120 pulses per revolution (PPR). If the motor is not started, or at zero speed, those numbers are zero and zero. If the motor is running with a steady speed reference, the reference and feedback pulse rates must be the same or the counter would saturate and the drive would be in current limit.

When a change is made from a steady state condition, such as an increase in speed command (starting from zero is an example), pulses are accumulated in the counter until the motor is drawing enough current to accelerate the shaft and return more pulses from the encoder than are coming from the reference. Each extra reference pulse increases the output current from the control. When the current is sufficient to accelerate the motor to a speed higher than that required by the reference pulses, the extra feedback pulses caused by the higher speed will reduce the current level until the reference pulses and the feedback pulses are again in balance.

Notice that this has nothing to do with the *frequency* of the pulse trains. The important thing is the *number* of pulses in the reference versus the *number* of pulses in the feedback pulse train. The counter stores the difference in the number of total pulses. As long as the counter does not saturate (an adjustable

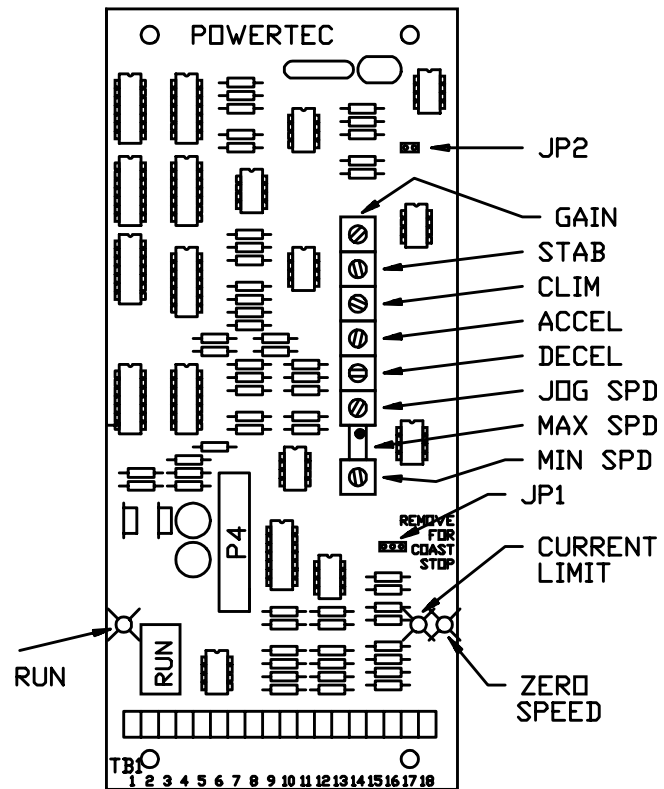

Figure 33: Major parts of the 141-107 Speed Controller board.

GAIN function), the motor will turn according to the number of pulses received.

LED indicators are provided for RUN, CURRENT LIMIT, and ZERO SPEED.

6.7 TROUBLESHOOTING

When troubleshooting the Model 4000, it is just as important to know WHEN something happens as it is to know WHAT happens. In other words, the SEQUENCE OF EVENTS is important in trying to resolve what, if any, problems there may be. There may be times when it seems that something is wrong, but the problem may actually be in the sequence of events.

A Start Up Procedure is shipped with each control. It should be used to put the unit into operation and may also be used to find problems. If problems are experienced in the operation of the control, go back and follow the start up procedure from the beginning, and make note of when and how things go wrong. This way, POWERTEC's service personnel will be able to pinpoint the problem more easily.

EFFECTIVE AND EFFICIENT TROUBLESHOOTING ALSO REQUIRES A SUPPLY OF SPARE PARTS FOR THE EQUIPMENT BEING WORKED ON.

Before attempting to do any troubleshooting, study figure 13 on page 14 (standard connection diagram), read sections 4 and 5 of this manual, and look at the power diagram (figure 28 on page 28) and the block diagram on page 32 (figure 31). This will familiarize you with the circuitry involved.

The LED indicators are designed to give a ready indication of the status of the control. They are an immediate visual reference of the present conditions in the drive, and may be used as a troubleshooting aid. It is recommended that the status of these LED's be checked frequently while starting up and/or troubleshooting the control.

Using the LED indicators, here are some suggestions as to possible problems and solutions, based upon the electrical wiring of the Model 4000 motor control (follow the suggestions in the order given):

PWR LED (green) This LED should be ON whenever there is power applied to the control. If the LED is not ON:

1. Check incoming power.
2. Turn off power, wait 3 minutes, and check fuses FU1, FU2, FU3, and FU4.
3. Re-apply power, and check the following power supplies:
 - TB2 terminal 12 is common
 - +24 VDC at TB2 terminal 8
 - +24 VDC at TB2 terminal 17
 - 24 VDC at TB2 terminal 3
 - +10 VDC at TB2 terminal 10
 - +5 VDC at TB1 terminal 8If supplies are O.K., the PWR LED may be bad.
4. Change Current Controller Board.

5. Change Driver Board.
6. Change power transformer T1.
7. Change entire controller.

BUSS LED (red on power-up, then green) This LED should be RED when power is first applied, then change to green within 30 seconds.

If it stays RED for more than 30 seconds:

1. Check incoming power.
2. Turn off power, wait 3 minutes, and check all fuses (including the one on the capacitor board).
3. Re-apply power and listen for the contactor CR3 on the chassis pulling in.
4. Replace Current Sensor Board.
5. Replace Current Controller Board.
6. Change entire control.

OV / UV (red) This LED will come on to indicate several adverse conditions which cause an electronic trip. If this LED comes on:

1. Check the incoming power.
2. Turn off power, wait 3 minutes, and check the fuses.
3. Reapply power and listen for the CR3 contactor pulling in.
4. Check the buss voltage (see capacitor board layout in figure 29 on page 30).

If buss voltage is greater than 1.6 times nominal line voltage for that unit, the trip is overvoltage (OV).

If buss voltage is less than 1.2 times nominal line voltage for the unit, it is under-voltage (UV).

It may be necessary to check the buss voltage while running under load.

5. Replace Current Sensor Board.
6. Replace Current Controller Board.

PL (red) This LED indicates one of several power problems on the incoming lines. If this LED is on:

1. Check the incoming power.
2. Turn off power, wait 3 minutes, and check the fuses.
3. Check incoming power while the control is running under load (it may be necessary to use an oscilloscope).
4. Change the Current Controller board.

IOC (red) This LED indicates dangerous current levels have occurred in the output transistors. If this LED is on:

1. If control will run, check motor current with AC clamp on ammeter while the motor is under load.
2. Disconnect motor and try to run.
3. Call POWERTEC service.

ENABLE (yellow) This LED indicates that the control is in the RUN mode (the RUN LED on the Speed Controller board should also be on) and there are no faults. If the motor is not running, a speed reference signal may be needed.

If this LED stays off, or goes off when a RUN command is given to the control:

1. Check to see if a trip indicator is on.

2. Check for +24 VDC at TB2 terminals 7, 5 and 4 (TB2 terminal 12 is common).
3. Make sure the ribbon cables are firmly seated.
4. Change the Current Controller board.
5. Change the Speed Controller board.

HS1, HS2, HS3 (red) These LED's indicate the operation of the LED switches as the motor turns.

If one or more of these LED's is not working:

1. See section 6.4 on page 33.
2. Check the hall sensors as in CURRENT LIMIT section under Speed Controller board below.

SPEED CONTROLLER 147-101

RUN (green) This LED indicates that the control is being given a RUN command.

If this LED is not on:

1. Check for +24 VDC at TB2 terminal 8, 7, and 4 (TB2 terminal 12 is common).
2. Change the Speed Controller board.
3. Change the Current Controller board.

CURRENT LIMIT (red) This LED indicates the UP/DOWN counter is saturated.

If this LED is on:

1. Make sure that the motor is physically capable of turning.
2. Check the current going to the motor (when the motor is stalled, this will require a DC amp probe).
3. Check the hall effect feedback terminals on TB1 while turning the motor by hand (the control power must be on, but the ESTOP circuit should be open).

TB1 terminal 1 is common

TB1 terminals 2, 3, and 4 will switch between 0 VDC and 8.8 VDC

TB1 terminals 5 and 6 will switch between 0 and 8.8 VDC, but at a much faster rate

TB1 terminal 7 is also common

TB1 terminal 8 is +5 VDC

ZERO SPEED (yellow) This LED indicates that the motor is turning faster than 10 RPM.

If this LED is not on:

1. Check to make sure the motor is turning.
2. Check the hall sensor input lights HS1, HS2, and HS3 on the Current Controller board.
3. Change the Speed Controller board.
4. Change the Current Controller board.

CURRENT SENSOR 144-9

THERMAL (yellow) This LED indicates that the heatsink thermal is closed (not overheated).

If this LED is not on:

1. Check for -24 VDC at TB3 terminal 9 (TB3 terminal 10 is common). CR3 should be energized.

2. Check for -24 VDC at TB3 terminal 6. If missing, and step 1 is correct, thermal is open or wire is broken.
3. Check the wires for loose or broken connections.
4. Change the Current Sensor board.
5. Change the heatsink thermal switch.

UNDERVOLTAGE (red) This LED indicates that an undervoltage condition of less than 80% buss level has occurred (this is a latching indication which is reset by the start/stop circuits).

If this LED is on:

1. Check the buss voltage across the entire buss and across each half of the buss (on 380VDC and 460VAC controls). CR3 should be energized. If the voltage is correct, press the stop button and restart the control. If it comes on again, or if it remains on, proceed to next step.
2. Check the voltage at the Current Sensor board from A to B (should be 0 VDC if CR3 is in). [See figure 29 on page 30 for locations of points A, B, and C]
3. Check the voltage from A to C on the Current Sensor board (it should be the buss level).
4. Change the Current Sensor board.

UNDERVOLTAGE TIME OUT (red) This LED indicates that power was lost at the input for at least 80 milliseconds, and/or an undervoltage condition of less than 80% buss level has occurred (this is a latching indication which is reset by the start/stop circuits).

If this LED is on:

1. Check the buss voltage across the entire buss and across each half of the buss (on 380VDC and 460VAC controls). CR3 should be energized. If the voltage is correct, press the stop button and restart the control. If it comes on again, or if it remains on, proceed to next step.
2. Check the voltage at the Current Sensor board from A to B (should be 0 VDC if CR3 is in). [See figure 29 on page 30 for locations of points A, B, and C]
3. Check the voltage from A to C on the Current Sensor board (it should be the buss level).
4. Change the Current Sensor board.
5. Change the Current Controller board.

OVERVOLTAGE (red) This LED indicates that an overvoltage condition of more than 115% buss level has occurred (this is a latching indication which is reset by the start/stop circuits).

If this LED is on:

1. Check the buss voltage across the entire buss and across each half of the buss (on 380VDC and 460VAC controls). CR3 should be energized. If the voltage is correct, press the stop button and restart the control. If it comes on again, or if it remains on, proceed to next step.
2. Check the voltage at the Current Sensor board from A to B (should be 0 VDC if CR3 is in). [See figure 29 on page 30 for locations of points A, B, and C]
3. Check the voltage from A to C on the Current Sensor board (it should be the buss level).
4. Change the Current Sensor board.

HOT (red) This LED indicates that the motor is overheated. Copyright 1993-1994 by POWERMAC Industrial Corporation. Used by permission.

DIODE MODULES

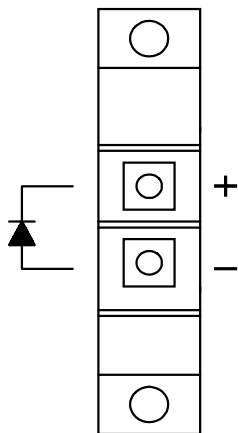
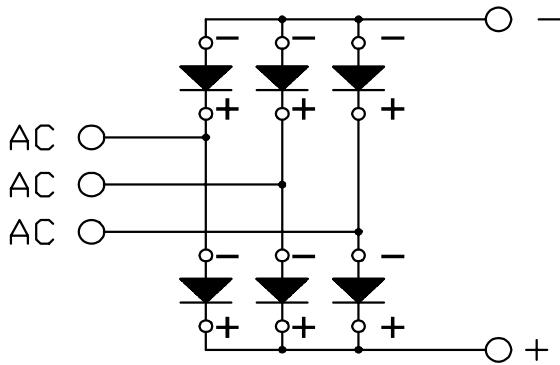

TRANSISTOR MODULES

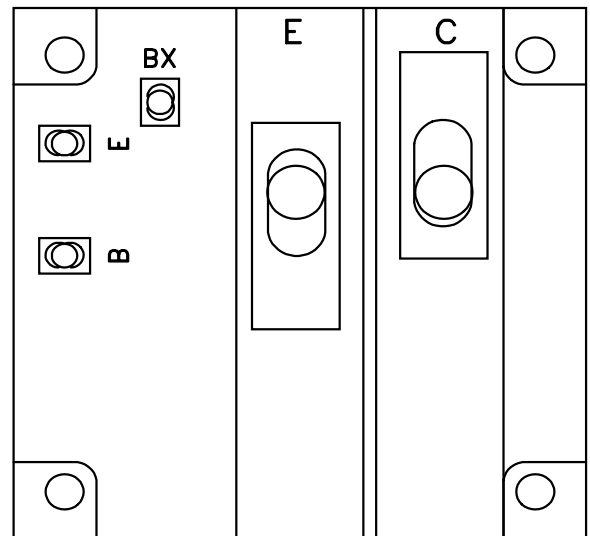
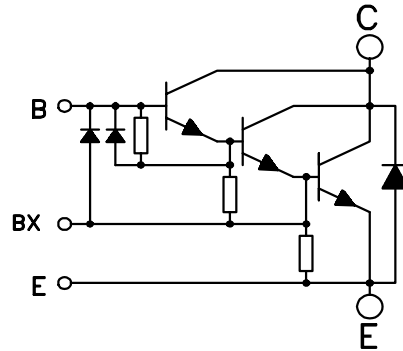

NOTE
 WHILE MOST MODULES ARE MADE TO STANDARD DIMENSIONS AND TO STANDARD CONNECTIONS, ALWAYS CHECK THE MARKINGS ON THE NEW MODULE IF YOU ARE REPLACING A COMPONENT.

THESE DRAWINGS ARE REPRESENTATIVE AND DO NOT NECESSARILY SHOW ALL CONFIGURATIONS WHICH MIGHT BE USED.

Figure 34: Some typical physical configurations of power semiconductors.

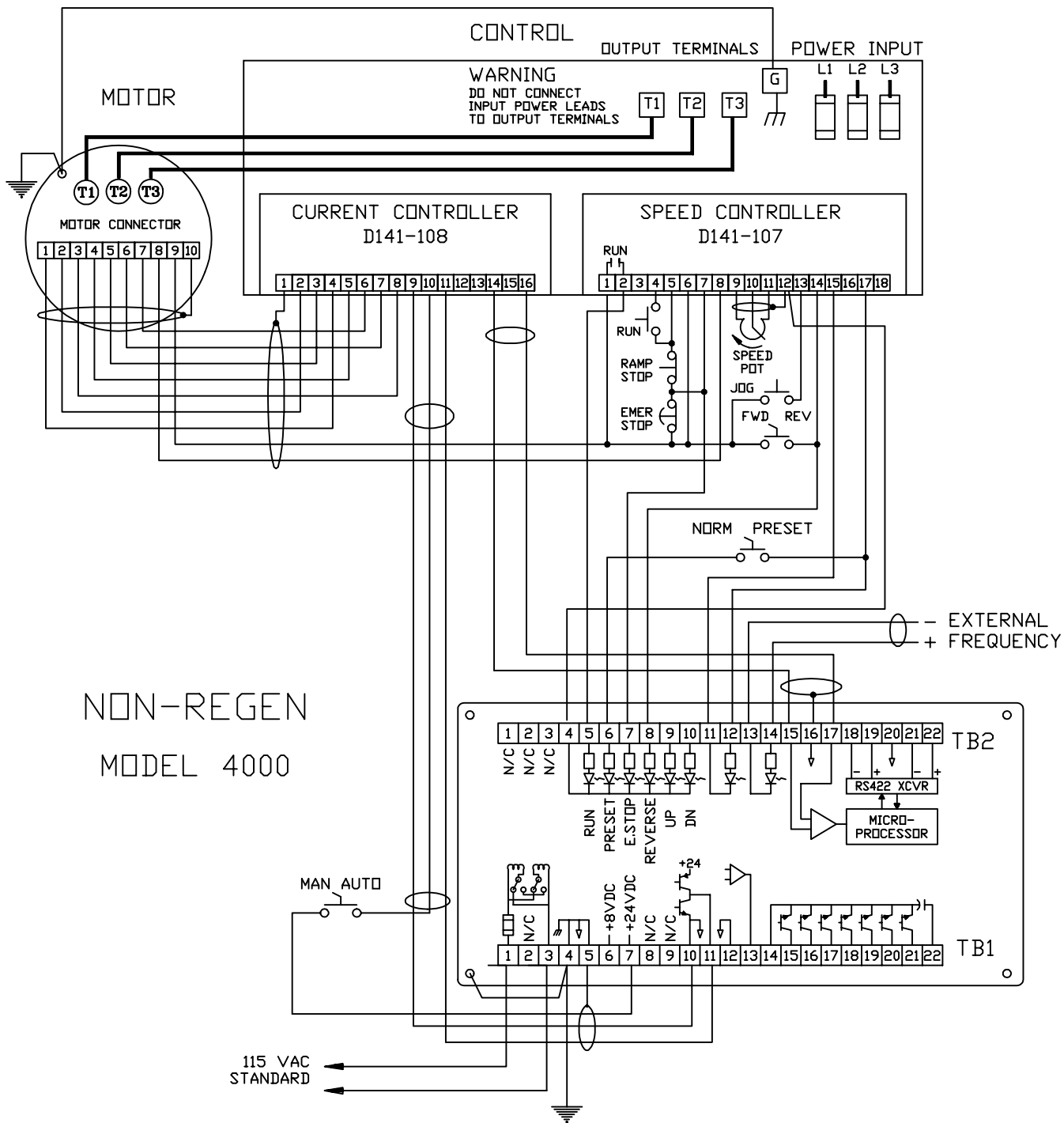

Figure 35: Connections of the Model 4000 to the optional **POWERTEC DIGIMAX IV**.

7.0 SPARE PARTS

Spare parts are necessary to assure continuation of service in the event that something goes wrong. The ability to effectively troubleshoot and repair motor controls requires that spare parts be available. It is strongly recommended that some or all of the following parts be carried in stock, and that at least one person become familiar with them and their usage in the repair of **POWERTEC** controls.

QUANTITY	DESCRIPTION	PART NO.
1	Current Controller PCB	141-108
1	Speed Controller PCB	141-107
1	Base Driver PCB	151-049
1	Current Sensor Board	144-9.3
3	Fuses F4, F5, F6	FNQ1/2
1	Fuse F7, F8	FNQ 2
1	Diode Bridge	See Below
1	Transistor Bridge	See Below
1	Transformer T1	151-49
1	Charge Resistor	P/FS02-65-500

H.P.	VOLTAGE	MODEL	DIODE	TRANSISTOR	MAIN FUSES
60	230	4000	IRKE91-12	KS621K60	FWH-250
75	230	4000	IRKE91-12	KS621K60	FWH-250
100	380	4000	IRKE91-12	KS621K60	FWH-250
125	380	4000	IRKE91-12	KS621K60	FWH-250
100	460	4000	IRKE91-12	KS621K40	FWH-250
125	460	4000	IRKE91-12	KS621K60	FWH-250
150	460	4000	IRKE91-12	KS621K60	FWH-250

When ordering spare parts, have the serial number of your control(s) handy. Parts may be substituted by **POWERTEC** due to availability. Older drives may have to use cross-referenced parts.

