

POWERTEC
INDUSTRIAL MOTORS
Subsidiary of Peerless-Winsmith, Inc.

Model 1000AR

Regenerative
Brushless DC Motor Control

**INSTALLATION AND
OPERATION**
INSTRUCTION MANUAL

JUNE, 2001

INTRODUCTION

WHAT IS A GENESIS SERIES BRUSHLESS DC DRIVE ?

The GENESIS series of Brushless DC (BLDC) motor controls (drives) were developed to operate very large Brushless DC motors. Large BLDC motors were first made by POWERTEC Industrial Corporation in the late 1980's. POWERTEC was acquired by Powertec in 1993.

Small BLDC motors have been in use for many years. The GENESIS series were the first drives produced to operate really large BLDC motors. They range from fractional Horsepower (HP) to 300 HP.

Brushless DC motors and drives offer three significant benefits to the user:

Absolute Speed Control

High Efficiency

Low Maintenance.

ABSOLUTE SPEED CONTROL

The AC induction motor must slow down, or "slip", in order to develop torque. The amount of slip varies with the load on the motor. When the load changes from no load to full load, speed may change by as much as 50 RPM. You must use extraordinary means to employ AC motors in speed sensitive applications.

Traditional brush-type DC motors have "IR Losses" that causes the speed of the motor to vary as the load changes. "IR Losses" cause speed changes of as much as 2% of base speed. You can limit speed changes to about 0.5% with a very expensive tachometer. That is still 8 or 9 RPM from no load to full load. You must use extraordinary means to employ brush-type DC motors in speed sensitive applications.

Brushless DC drives and motors do not change speed when the load changes. This is true with the *standard product*, right out of the box! This is very good for speed sensitive applications.

HIGH EFFICIENCY

AC induction motors are relatively efficient when operated across the line on plant power. Using an AC variable speed inverter to control the speed of the motor adds power losses as heat in the drive. It also creates additional losses in the motor. At the 100HP level, the total losses in the AC system approach 10%.

Brush-type DC motor systems at 100 HP are relatively efficient, but the losses total about 8%.

Brushless DC systems at the 100 HP level average less than 6%.

At 100 HP, each percentage of losses is 750 watts. That's 18 KiloWatt-Hours (KWH) per day, or about 6,500 KWH per year. A 2% difference in efficiency results in over \$1,000 a year in direct energy savings.

LOW MAINTENANCE

AC induction motors running on variable speed AC drives produce a lot of heat. The motors require more frequent lubrication. They also need extra bearing changes. Heat also shortens the life of the motor.

Brush-type DC motors require frequent brush replacement. They also need commutator service and field and armature rewinding. They also require frequent lubrication and bearing changes due to heat.

Brushless DC motors require lubrication. However, the oversize bearings and the low heat production in the motor allow long bearing life. Maintenance on a Brushless DC motor is minimal.

POWERTEC offers the GENESIS series for general purpose industrial use .

POWERTEC also offers a complete line of servo-duty rated drives and motors covering the range from 1/10 to 300 HP.

SPECIFICATIONS

Environmental

ALTITUDE :	Use above 3300 feet (1000 meters) requires de-rating. De-rate at 3% of full rating for each additional 1100 feet (330 meters).
STORAGE TEMPERATURE :	-40 °C to +65 °C (-40 °F to + 150 °F)
AMBIENT TEMPERATURE :	
Chassis :	Maximum air temperature of 55 °C (131 °F).
Nema1 :	Maximum air temperature of 40 °C (104 °F).
RELATIVE HUMIDITY :	Less than 95%, non-condensing.
POWER SOURCE :	
Voltage :	Nominal 230 VAC, 380 VAC, or 460 VAC per nameplate rating.
Voltage Tolerance :	-10%, +10% of nominal rated voltage.
Phases :	Three (Drive will not operate on single phase).
Frequency :	48 to 62 Hertz
KVA Required :	KVA rating of source must be at least equal to Horsepower rating.
Max KVA Rating :	100 KVA (limited by input fuse AIC rating).

Dimensions

Physical Dimensions :	See page 8.
Approximate Weights :	
1000AR chassis :	75 pounds (34 kg).
1000AR Nema1 :	110 pounds (50 kg)

Performance

Maximum Load :	150% for 1 minute out of 10 minutes.
Speed Regulation :	0.0% (on load change from no load to full load)
Speed Accuracy :	
Analog Mode :	+/- 1.0% typical with speed pot supplied by internal reference.
Linearity :	+/- 0.5% typical with external reference source.
Digital Mode :	0.0 % typical (+/- 3/4 revolution of the motor shaft).
Displacement power factor :	0.96 typical

Adjustments

ACCELERATION TIME :	2 to 90 seconds with JP2 installed; 0.05 to 2 seconds with JP2 removed..
DECELERATION TIME :	2 to 90 seconds with JP2 installed; 0.05 to 2 seconds with JP2 removed..
	Acceleration and deceleration times settable in analog mode only.
MAXIMUM SPEED :	600 to 5000 RPM (motor dependent), analog mode only.
MINIMUM SPEED :	0 to 15% of MAXIMUM SPEED with 5K speed potentiometer, analog mode only.
JOG SPEED :	0 to 30% of MAXIMUM SPEED, analog mode only.
CURRENT LIMIT :	Adjustable from 0% to 150% of rated current, calibrated by Horsepower Resistor.
GAIN :	10 to 1 stiffness ratio
STABILITY :	20 to 1 dynamic response.

Jumpers

See Page 32

LED Indicators

See Page 36

Terminal Assignments

See Page 22

REGENERATIVE VERSUS NON-REGENERATIVE OPERATION

Traditional AC induction motors and brush-type DC motors have windings on the rotor. They also have stationary windings on the frame that produce magnetic fields if we energize them. When the motor rotates, the windings move through the magnetic field.

If we externally force the shaft to turn, this movement through magnetic fields produces a potential at the motor's power terminals. We call this potential "Electro-Motive-Force" (or EMF, for short). The motor is now a generator, and it is capable of supplying power if we keep the stationary windings energized.

In the case of the Brushless DC motor, a field produced by the permanent magnets on the rotor moves around the stationary windings on the frame. We do not have to keep the windings energized to produce power. You will see the importance of this in dynamic braking (below).

A motor is running in the MOTORING mode when it is drawing current from the power supply. The motor is changing electrical energy into mechanical work at the motor shaft. This is the most common mode of motor operation. The motor still produces the same potential at its terminals, but we call it "Counter-EMF" (CEMF) when the motor is in the motoring mode. CEMF opposes the flow of current from the supply to the motor.

From the generator action, we derive the term REGENERATING. This indicates that the motor is no longer drawing current from the supply. It is now returning current to the supply.

The motor can not draw current from the supply if the voltage produced by the rotation of the motor shaft (the CEMF) exceeds the supply voltage. We see this condition when motor speed is greater than the speed commanded by the speed reference. The load inertia may be greater than the amount of inertia that the motor can slow down in the time allotted. External forces can drive the load faster than desired.

A load in motion will "coast" to a free-wheeling stop. Speed, inertia, and friction of the load determine how

long the stopping will take. The faster a load is moving, the longer the load requires to stop. Larger inertias (more mass) take longer to stop, but a higher friction load slows it down faster. A moving load stops in a coasting situation by dissipating the energy of motion as frictional heat, which acts as a brake. If inertia is high and friction is low, the load will take a longer time to stop. We can use mechanical brakes to increase the amount of friction.

A non-regenerative drive can not slow down a load in less time than the load would slow down by itself. It cannot act as a brake. We can supply braking force by making the motor act as a generator. We can dissipate the energy of the inertia into passive resistors, but we cannot connect the resistors until after we shut off the drive (dynamic braking). With AC motors and brush-type DC drives, we must keep the stationary fields energized, but not with BLDC. Even if we lose drive power or plant power, dynamic braking still works.

Regenerative drives can supply braking force while the motor control is active. A motor that operates on a regenerative drive becomes a generator when it rotates at a speed faster than set speed. The amount of power generated relates to the speed, inertia, and friction of the load and motor. The regenerative drive accepts

the current from the motor, and dissipates the energy. The dissipative load presented by the controller must be adequate.

When the motor generates energy, and the drive receives it, then the motor is REGENERATING. A motor in the regenerating mode develops torque in the opposite direction of its rotation. It is not drawing power from the supply, as it is in the motoring mode.

Regenerative power capability gives motors and controls the ability to change from higher speeds to lower speeds quickly. This includes zero speed and the reversal of motor direction. This happens much more quickly than with non-regenerative types of controls. The result is more rapid stops and reversals of loads that would otherwise be a lot more sluggish in these actions.

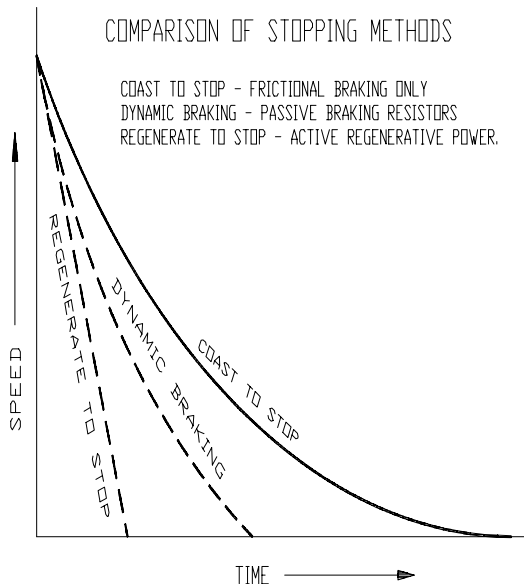

MODEL 1000AR STANDARD CONNECTIONS

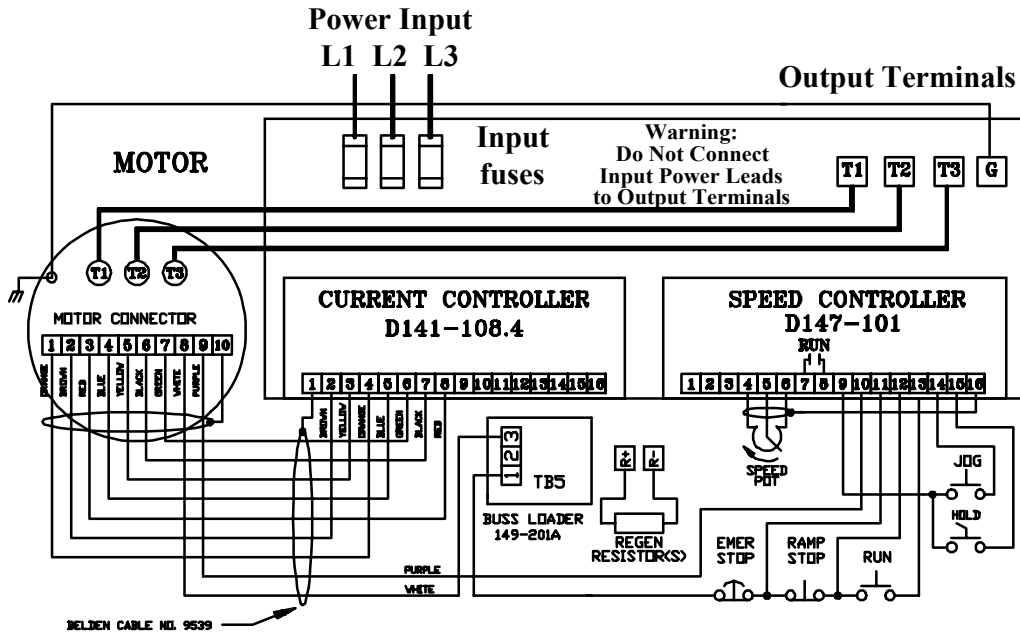

CURRENT CONTROLLER BOARD

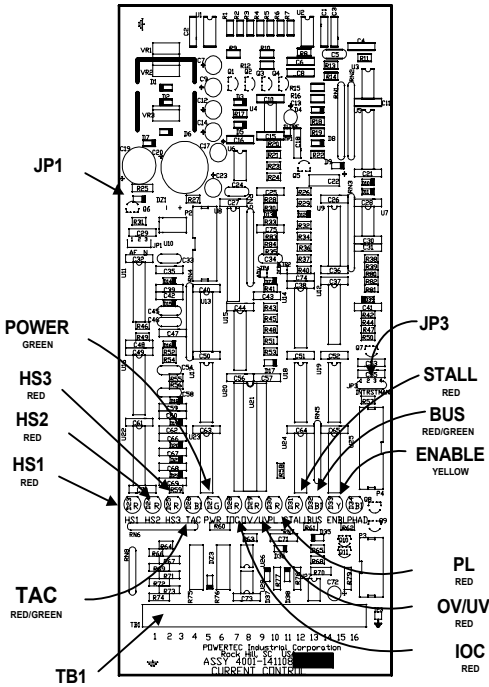

REGEN SPEED CONTROLLER 147-101

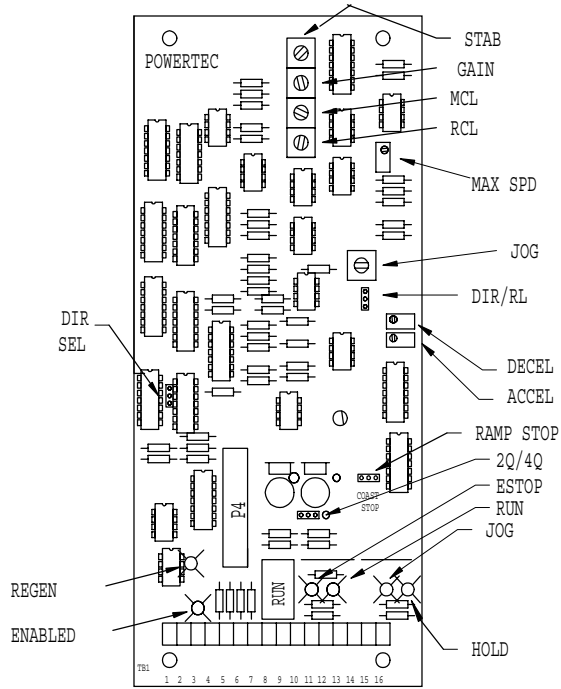

QUICK START

Follow these steps to quickly set up and operate the Model 1000AR Brushless DC drive. If you are not sure of the procedure for any of the steps, consult the installation section (beginning on page 9).

CONNECTIONS

1. Connect the proper three-phase AC power from a suitably rated switching device to the input terminals L1, L2, and L3. Check the nameplate. The sequence of the phases is not important to the drive.
2. Connect the power system ground to the GND terminal. Make sure the system ground is earth ground.
3. Connect T1 of the motor to T1 of the drive. Connect T2 to T2, and T3 to T3. The order of connection is important. The motor will not run with improper motor connections..
4. Connect a ground wire from the motor's ground lug to the GND terminal on the drive.
5. Connect the resistor to R+ and R- terminals on the chassis. If you have a separate bus loader, see page 21.
6. Connect the encoder cable to the motor. Consult the drawing on page 4. The cable used should be a nine-conductor shielded cable. The colors do not matter, but they aid in tracing wires. Connect the shield at both ends of the cable (the shield continues inside the motor, but is not connected there).
7. Connect a 10 Kilo-ohm Speed Potentiometer to TB2 terminals 4 (CW), 5 (Wiper), and 16 (CCW). Connect the shield of the speed pot cable to TB2 terminal 16. To reverse rotation connect CW to TB2 terminal 6.
8. TB2 terminal 10 should be connected to the motor thermal (cable). The other side of the motor thermal should be connected to TB5 terminal 3 (bus loader). Connect an Emergency Stop (ESTOP) button between TB3 terminal 1 and TB2 terminal 11. Use a normally-closed, maintained-open contact type pushbutton.
9. Connect a normally closed, momentary type, STOP pushbutton between TB2 terminals 11 and 12.
10. Connect a normally open, momentary type, RUN pushbutton between TB2 terminals 12 and 13.
11. If desired, connect a normally open, momentary type, JOG pushbutton between TB2 terminals 9 and 14.
12. If desired, connect a normally open, momentary type, HOLD pushbutton between TB2 terminals 9 and 15.

START UP

1. Before applying power, turn the speed pot fully counter-clockwise (CCW) and turn the MCL and RCL potentiometers fully counter-clockwise. Do not connect the motor to a load for its initial run..
2. When you apply power, the PWR LED should light up GREEN immediately.
3. When you apply power, the BUS LED should light up RED immediately.
4. When power is on, the HS1, HS2, and HS3 LED's may or may not be on RED, depending on the position of the motor. Only one or two should light; never all three and never none.
5. When power is on, the TAC LED may be OFF, RED, GREEN, or ORANGE.
6. Within 30 seconds, the BUS LED should turn GREEN and the you should hear the charging contactor click as it energizes. If this does not happen within 30 seconds, shut power off and consult the troubleshooting section.
7. The ESTOP LED should be ON GREEN on the Speed Controller board.
8. Press and release the START button. The RUN LED should light GREEN. The CURRENT LIMIT LED may come on GREEN at this time because the MCL pot is all the way counter-clockwise.
9. Immediately after the RUN LED comes on, the ENABLE LED should light on both boards.
10. Increase the speed pot reference to about 10% of its rotation from the CCW position.
11. Turn the MCL pot slowly clockwise. If the motor does not turn (HS1, HS2, HS3, and TAC will start blinking) before MCL is at 50%, turn the MCL pot back down fully CCW. Consult the troubleshooting section.
12. Leave the MCL pot at 50 % and increase the speed pot to 50% of its rotation. Check the motor speed with a hand-held tachometer. Adjust the MAX speed pot, if necessary to attain 50% speed.
13. Turn the speed pot to 100% and measure the motor speed. Adjust MAX speed if necessary.
14. Press the Normal Stop button and start again. Time the acceleration to full speed and set ACCEL time.
15. Turn the RCL pot to 50%. Turn speed pot to 0% (CCW) and time decel ramp. Adjust DECEL for correct time.
16. Set STAB and GAIN to 50%. Press the Normal Stop button. Both ENABLE LED's should go OFF.
17. Run the motor at high speed and push the HOLD button. The HOLD LED should light RED. The motor should stop. Release the button and the motor should return to the previous speed.
18. Press Stop. Press the JOG button. The JOG LED should light GREEN. Set the JOG speed, if desired.
19. The motor is ready for service.

REFERENCE PAGES

Specifications.....	2
Model 1000AR Standard Connections.....	4
Model 1000AR Dimensions Chart	10
Model 1000AR AC Input Electrical Ratings Table	12
Model 1000AR Output Electrical Ratings Table	14
Regenerative Resistors	16
Contactors Specifications	18
Dynamic Braking Resistors	18
Model 1000AR Control Connections Table	20
Terminal Descriptions List	22
PLC Interface Suggestions	24
Digital Mode Notes	26
Analog Versus Digital Operation Comparison	28
Standard Basic Connection Diagram	30
Capacitor Board Location and Layout	32
Current Controller Board Layout	34
Speed Controller Board Layout	34
Jumpers List	34
LED Indicators - Current Controller Board	36
LED Indicators - Speed Controller Board.....	38
Adjustments	40
Simplified Power Schematic	42
Semiconductor Diagrams.....	42
Transistor Module Static Test	44
Diode Bridge Test	46
Transistor Leakage Test.....	46
Encoder Waveforms and Connections	48
IOC Tests.....	50
OV/UV Tests	50
Block Diagram - Speed and Current Controller boards	52
Base Driver board- Layout and Connections.....	54

TABLE OF CONTENTS

INTRODUCTION	1
REGENERATIVE ... OPERATION	3
QUICK START	5
REFERENCE PAGES INDEX	6
MOTOR PROTECTION	9
WARRANTY	9
 INSTALLATION	
<u>How Do I ...</u>	
Physically Install the Model 1000AR Drive ?.....	11
Connect AC Power to the 1000AR Drive ?	13
Connect the Motor to the 1000AR Drive ?	15
Connect the Regenerative Resistors to the Model 1000AR?	17
Install an Output Contactor ?	19
Install Dynamic Braking ?	19
Connect Standard Control Circuits ?	21
Get RUN , Zero Speed, FAULT , and ENABLE Information ?	23
Connect an ANALOG Speed Reference ?.....	25
Connect a DIGITAL Speed Reference ?.....	27
Connect a DIGIMAX® ?	29
Installation Checklist	31
 START UP	
<u>What Happens When I ...</u>	
Apply Power to the Model 1000AR Drive ?	33
Give the Start Command to the Model 1000AR Drive.....	35
Give the Speed Command to the Model 1000AR Drive	37
Slow down or Overhaul the Model 1000AR.....	39
Make an Adjustment on the Model 1000AR Drive.....	41
 TROUBLESHOOTING	
<u>Troubleshooting Chart</u>	
Troubleshooting the Model 1000AR Drive.....	43
Troubleshooting Chart - POWER LED	45
Troubleshooting Chart - BUS LED.....	47
Troubleshooting Chart - HS1, HS2, HS3, and TAC LED's	49
Troubleshooting Chart - RUN and ENBL LED's	51
Troubleshooting Chart - TAC and ZERO SPEED LED's	53
Troubleshooting Chart - CURRENT LIMIT and PHAD LED's	55

INSTALLATION

Underwriter's Laboratories® requires this notice for UL® listed equipment.
This Notice applies to POWERTEC Brushless DC Drive Model Number 1000AR.

Do not use this device on a circuit capable of delivering more than 5000 RMS symmetrical Amperes at 500 VAC maximum voltage.

MOTOR PROTECTION CONSIDERATIONS

You are installing a **GENESIS** Series Brushless DC (BLDC) drive and motor. You must consider how the motor will be protected while it is in service. These protections built into your system:

1. **"F" Series** motors have a thermal switch that opens at high winding temperatures. You must connect this switch to the drive. Look up the method of connection in the drive manual. When the thermal switch opens, the drive must shut off before high temperatures cause damage.
2. The Model 1000AR drive provides current limiting. This protection is adjustable from 0% to 150% of the drive's rated output current.
3. The Model 1000AR drive provides an over-current trip. The drive shuts off the drive if peak currents greater than 300% of the RMS rating occur.
4. The Model 1000AR drive provides fast clearing fuses in the AC input. It does not provide an input circuit breaker unless you chose that option at the time of purchase. If you did not purchase a circuit breaker with the drive, you must supply a means to disconnect main power.. You must do this in order to meet the requirements of the National Electrical Code.
5. **GENESIS** series drives do not provide running overload protection as described in Underwriters Laboratories Industrial Control Equipment Specification 508. The user is responsible for complying with local codes and practices. If you decide that you need more protection, that protection must shut off the drive.

SUMMARY OF WARRANTY AND DISCLAIMER

Powertec manufactures Model 1000 Series Brushless DC (BLDC) motor controls. We warrant these units against defects in materials and workmanship for a period of two years. This period begins on the date of original shipment from the factory.

You must notify us in writing of a defect in materials or workmanship in a warranted unit. We will, at our sole option, repair or replace such defective parts as we deem necessary to restore the unit to service. We will make these repairs, or replacement of parts, at the factory. Shipping charges to and from the factory and on-site service charges are the responsibility of the user.

There is no other warranty. We do not warrant the fitness of purpose for the application intended. This warranty does not cover accidental or intentional damage or accidental or intentional abuse. This warranty does not cover results from defective or incorrect installation, interference with other equipment, or any other situation over which **Powertec** has no control.

This warranty does not cover any other claims, including, but not limited to, special, incidental, or consequential damages.

Powertec supplies this manual as a guide to the use of our products. We have used our best efforts to compile this information. If you find mistakes of fact in this manual, please notify your distributor or **Powertec** at once.

MODEL 1000AR DIMENSIONS

CHASSIS UNITS

Note: 10HP @ 230VAC, 10HP @ 380VAC, and 15HP @ 460VAC have the same dimensions, but they have separately mounted bus loaders

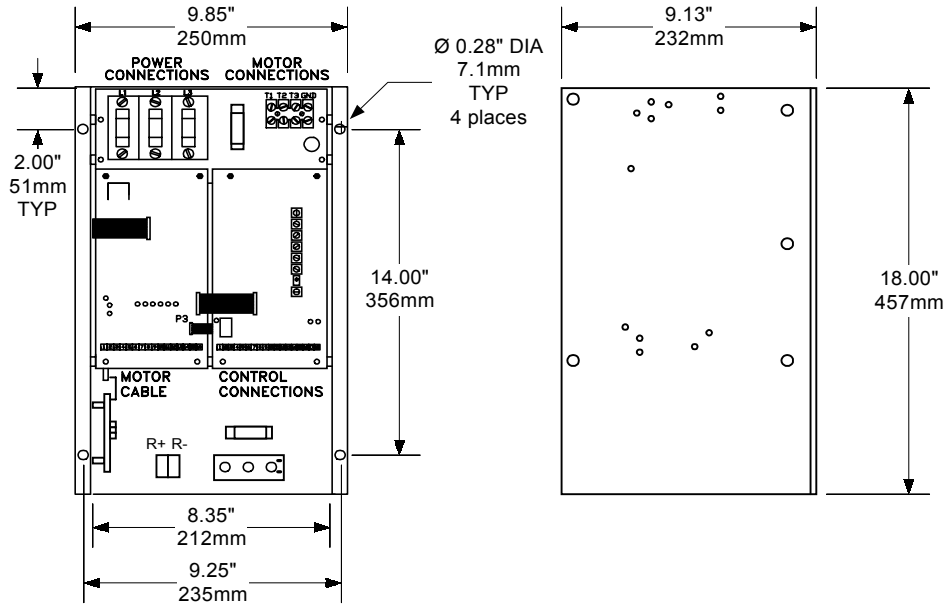

ENCLOSED UNITS

Note: Units with separately mounted bus loaders come in a 34"H x 24"W x 18"D Nema1 Enclosure.

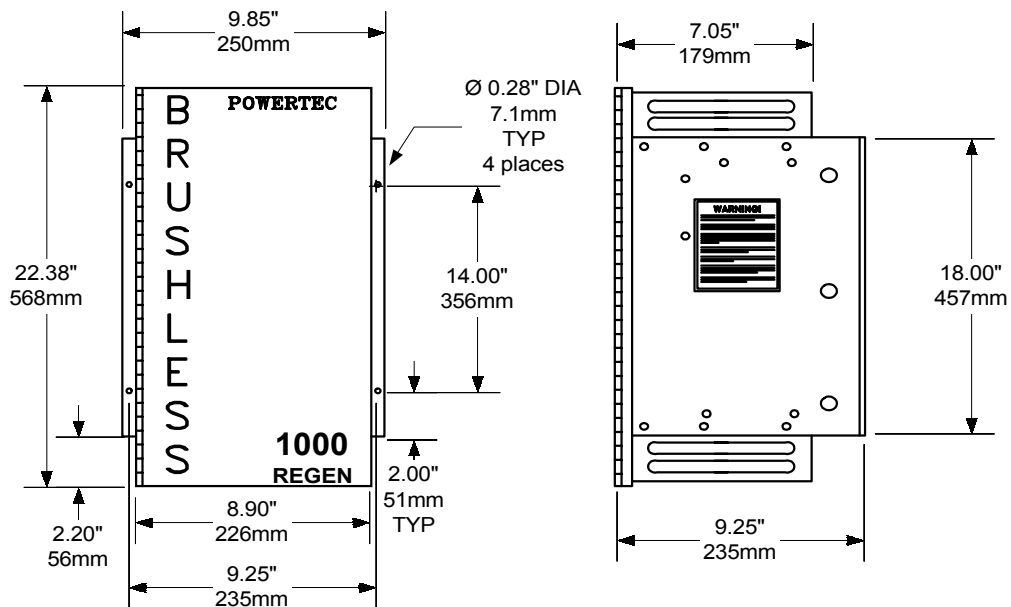

ALL DIMENSIONS ARE APPROXIMATE. Consult factory for certified dimensions.

HOW DO I ...

PHYSICALLY INSTALL THE MODEL 1000AR DRIVE?

Use of the Model 1000AR drive above 3300 ft (1000 meters) requires de-rating.
 If the drive is to be stored, store it in its original packaging in a dry environment.
 Storage temperature should be between -40°C and +65°C.

WARNING: DANGEROUS HIGH VOLTAGES ARE NORMAL IN THIS EQUIPMENT! WHEN THE AC INPUT POWER IS REMOVED, THE CAPACITORS ARE NOT DISCHARGED AT ONCE! BE SURE INPUT POWER IS OFF AND CAPACITORS ARE DISCHARGED BEFORE WORKING ON THE MOTOR OR THE DRIVE.

WARNING! : IF YOU TESTED THE DRIVE BEFORE INSTALLATION MAKE SURE THAT THE BUS HAS DISCHARGED.

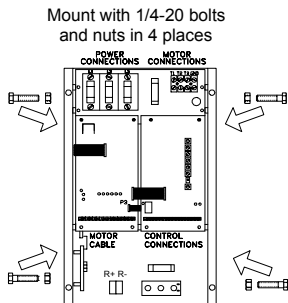

Mount a Model 1000AR drive of the NEMA 1 style with the fuses at the top. Free air must flow up through the fins on the back of the drive.

The temperature of the air around the drive (the ambient) must not exceed 40°C (104°F) with a relative humidity of 95% or less.

Leave at least 6 inches (150 mm) open space on all sides of a NEMA1 box. Do not mount it directly above a heat source, such as another drive. There must be at least 18 inches (450 mm) open space between the units.

When you move a drive chassis, DO NOT handle the chassis by parts that may bend or come loose. This applies to the front cover of the drive.

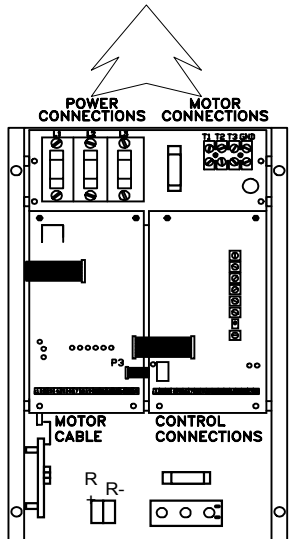

Mount the chassis style Model 1000AR drive in an upright position (fuses at top) inside an enclosure to promote air flow through the heatsink.

The temperature of the air around the chassis unit may not exceed 55 °C (131 °F). Relative humidity must be 95% or less, and non-condensing.

Avoid mounting one chassis directly above another. This will result in hot air from the lower chassis flowing up into the upper chassis. Leave at least 12 inches (300 mm) of open space between them.

There must be free panel space of at least 3 inches (75 mm) above and below the chassis.. This allows air flow through the heatsink fins.

The total heat dissipation within the electrical enclosure determines its size. A list of heat outputs of the Model 1000AR is in the table on page 6.

NEMA1 and NEMA12 ventilated boxes depend on air flowing through the enclosure for cooling. They must have an air flow of 1 CFM (cubic feet per minute) per 10 watts of dissipation (1 cu meter / min per 350 watts).

The allowance for totally enclosed units is 1 square foot of enclosure surface per 7 watts of dissipation (75 watts per square meter). Surface area includes front, sides, top and bottom surfaces. Enclosure surfaces not exposed to cooling air do not count.

For further information, consult the publication *THERMAL MANAGEMENT*, available from your distributor.

If a separate bus loader has been supplied, mount it on the panel near the drive. Mount it with the fins vertically oriented, and make sure that air can flow through its heatsink.

Bus Loader Resistors become VERY HOT in the performance of their duty. Bus loader resistors must be mounted OUTSIDE THE ENCLOSURE in a dry, well ventilated area, where there are no flammable materials. Bus loader resistors are supplied in an expanded metal cage for wall mounting.

MODEL 1000AR AC INPUT ELECTRICAL RATINGS

	NOMINAL AC LINE VOLTAGE	HORSE- POWER	KILO- WATTS	MAXIMUM CONTINUOUS AC LINE CURRENT	INPUT KVA	MAXIMUM HEAT OUTPUT IN WATTS
	230	½	0.37	1.4	0.550	35
	230	¾	0.56	1.8	0.725	42
	230	1	0.75	2.4	0.950	60
	230	1.5	1.1	3.6	1.450	85
	230	2	1.5	4.9	1.950	122
	230	3	2.2	7.3	2.900	165
	230	5	3.7	12.1	4.825	232
	230	7.5	5.6	18.1	7.200	281
‡	230	10	7.5	23.9	9.525	385
	380	1	0.75	1.5	0.975	36
	380	1.5	1.1	2.2	1.450	55
	380	2	1.5	2.9	1.925	70
	380	3	2.2	4.4	2.875	105
	380	5	3.7	7.3	4.810	142
	380	7.5	5.6	10.9	7.150	178
‡	380	10	7.5	14.1	9.250	222
	460	2	1.5	2.4	1.910	113
	460	3	2.2	3.5	2.800	144
	460	5	3.7	5.9	4.750	200
	460	7.5	5.6	8.9	7.100	258
	460	10	7.5	11.4	9.050	355
‡	460	15	11	17.8	14.150	475

‡ Indicates drives supplied with separate bus loader.

Notes

The Model 1000AR drives will operate on power line frequencies from 48 to 62 hertz.

The **tolerance** of the input voltage is +10% to -10% of the voltage listed on the nameplate. A service must be capable of supporting the starting current of AC motors without dropping more than 10%. Brief power line disturbances may trip a drive supplied with less than 95% of the nominal line voltage.

Do not measure the input voltage while the drive is not running. This neglects the effects of load on the power source. Measure the actual input line voltage while the control is operating the motor in a loaded condition.

Brief power line disturbances will not normally disturb the Model 1000AR drives. The Model 1000AR drives do not generate significant noise back onto the power service. Events that distort the AC waveform may lower the bus voltage. These may trigger an under-voltage or power loss condition.

One of the most frequent problems encountered with digital type equipment is electrical noise. Noise is a treacherous problem that is capable of causing destructive results. It can also cause intermittent and annoying problems. The methods used in the installation of the equipment plays a large part in prevention of electrical noise problems in operation. Any digital type control requires that extra care be taken in installation. Pay attention to the grounding of the equipment, the shielding of wires and cables, and the placement of wires in the conduit runs. Pay attention to the sections of this manual that address the precautions against noise. This also applies to peripheral equipment.

When you use other manufacturer's equipment in a system, follow their directions regarding noise suppression and protection. Pay particular attention to power and grounding requirements.

HOW DO I ...

CONNECT AC POWER TO THE 1000AR DRIVE?

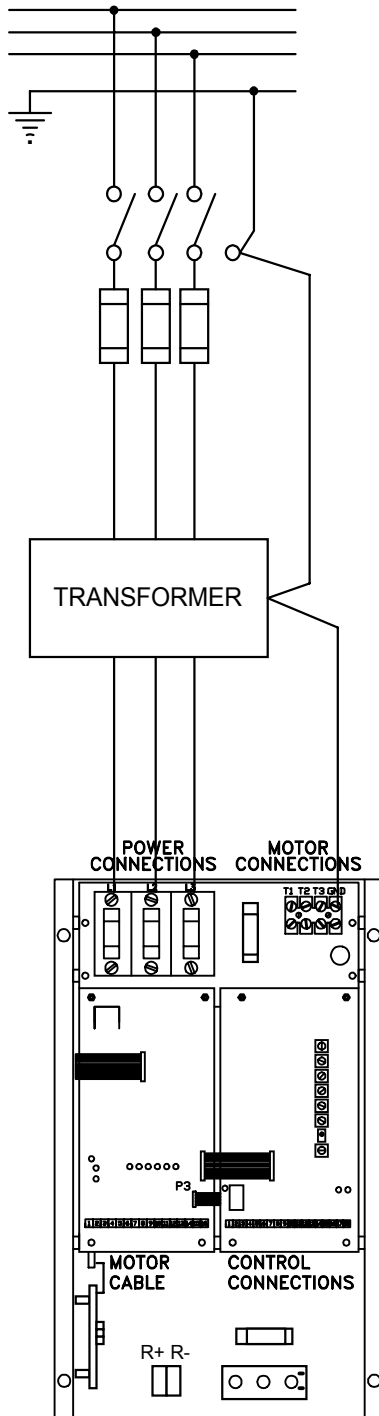

Standard Model 1000AR Brushless DC drives will not operate on single phase AC power.

Model 1000AR drives require a three-phase main power source with a **KVA rating** at least equal to the **HorsePower rating** of the drive. Power is NOT returned to the power line during regeneration.

The branch service rating (in KVA) supplying the drive must not be more than 10 times the HP rating of the drive. If it is, you may need special disconnecting means with a higher AC short-circuit current interrupting capacity.

Model 1000AR drives do not include a disconnecting switch for input power. The user must supply a switch that meets the applicable code requirements.

The maximum Interrupting Capacity (AIC) of the fuses is 5,000 amperes. You will need a switch with a rating greater than 5,000 amperes if the short circuit current on the service is greater.

You do not *necessarily* need an ISOLATION TRANSFORMER for operation of the drive. You may want to use one, or you might need to meet local code requirements. You need to change the voltage level.

In those cases, you will need a transformer with a KVA rating at least as large as the HP rating of the drive. If you use a transformer, we recommend a delta/wye winding configuration. We also recommend that the transformer have taps to raise or lower voltage.

The user protection supplied before the wires determines the sizes of the power wires to the drive input. The table on the opposite page lists the full load AC line currents of Model 1000AR drives.

The order of connection of the input phases is not important.

We size the main fuses to protect the semiconductor elements of the unit. THEY MAY OR MAY NOT MEET THE REQUIREMENTS OF NATIONAL, STATE AND/OR LOCAL ELECTRICAL CODES. The responsibility for meeting the branch service protection and other code requirements and safety codes belongs to the user.

NOTICE: AC LINE CURRENT OF THE BLDC DRIVE IS NOT REPRESENTATIVE OF MOTOR LOAD CURRENT!

The AC input current is directly proportional to the POWER output of the motor. The only time the AC line current reaches its full value is when the motor is operating at full speed with full load.

DO NOT ATTEMPT TO MEASURE MOTOR LOAD BY MEASURING AC INPUT LINE CURRENT TO THE BLDC MOTOR CONTROL.

MODEL 1000AR FUSE BOARD

A.C. POWER
INPUT

MOTOR
CONNECTIONS

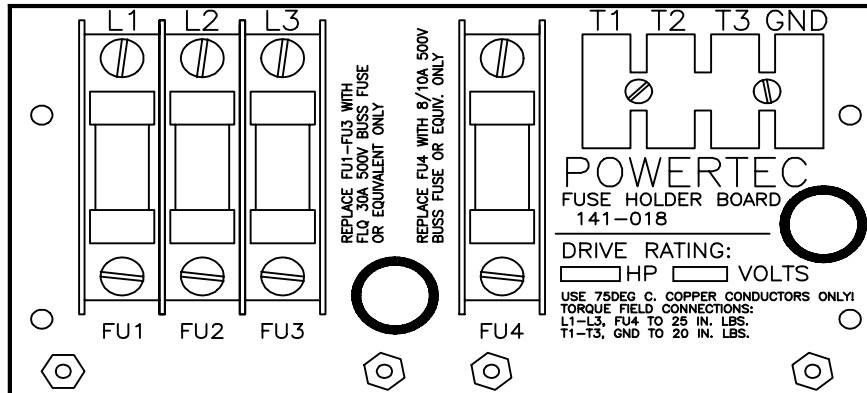

Model 1000AR Output Electrical Ratings

	NOMINAL AC LINE VOLTAGE	HORSE- POWER	KILO- WATTS	MAXIMUM CONTINUOUS MOTOR CURRENT	MAXIMUM MOMENTARY MOTOR CURRENT	NOMINAL HP CALIBRATE RESISTOR
	230	½	0.37	2.2	3.3	68.1 K
	230	¾	0.56	3.4	5.1	45.3 K
	230	1	0.75	4.7	7.0	33.2 K
	230	1.5	1.1	7.0	10.5	22.1 K
	230	2	1.5	8.5	12.7	18.2 K
	230	3	2.2	12.8	19.2	12.1 K
	230	5	3.7	22.8	34.2	6.81 K
‡	230	7.5	5.6	31.1	46.6	4.99 K
‡	230	10	7.5	41.5	61.1	3.74 K
	380	1	0.75	2.7	4.0	56.2 K
	380	1.5	1.1	3.9	5.8	39.2 K
	380	2	1.5	4.7	7.0	33.2 K
	380	3	2.2	7.8	11.7	20.0 K
	380	5	3.7	14.1	21.1	11.0 K
‡	380	7.5	5.6	18.8	28.2	8.25 K
‡	380	10	7.5	25.0	37.5	6.19 K
	460	2	1.5	4.0	6.0	39.2 K
	460	3	2.2	6.9	10.3	22.1 K
	460	5	3.7	11.6	17.4	13.3 K
	460	7.5	5.6	17.1	25.6	9.09 K
‡	460	10	7.5	20.7	31.0	7.50 K
‡	460	15	11	31.1	46.6	4.99 K

‡ Indicates 1000A models.

HOW DO I ...

CONNECT THE MOTOR TO THE 1000AR DRIVE?

We ship every drive from the factory with A STANDARD CONNECTIONS card.

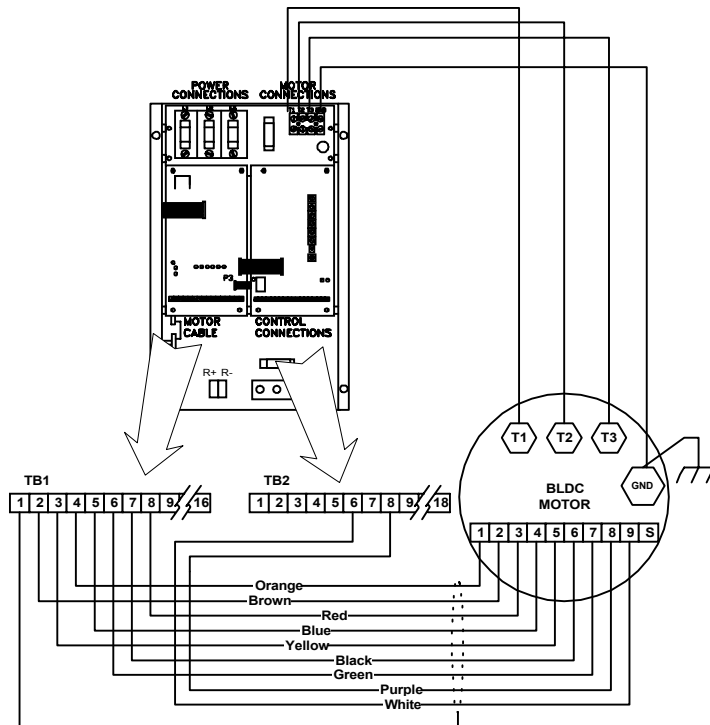

Connect the motor lead marked T1 to the T1 terminal on the drive. Connect the T2 lead to T2 on the drive, and connect T3 to T3. Other connections to T1, T2, and T3 at the motor will vary with the motor. The motor will not operate if the power wires from motor to drive are not in the proper order.

Full load motor current determines the wire size to the motor. The table on the opposite page lists these currents.

Any high voltage, high frequency equipment generates EMI and RFI. **YOU MUST USE METALLIC CONDUIT TO ENCLOSE MOTOR WIRES BETWEEN THE MOTOR AND THE DRIVE.** This will minimize interference.

You must install a ground wire between the motor frame and the drive chassis. There is a ground lug in most motors. If there is no ground lug, make a connection at any bolt in the motor junction box.

THIS GROUND WIRE MUST BE RUN IN ADDITION TO GROUNDING THE MOTOR FRAME TO ITS MOUNTING, WHICH IS REQUIRED BY CODE.

The purpose of this separate ground is to equalize the potential between the motor's frame and the drive chassis. There may be enough impedance to broadcast EMI and RFI even with the motor grounded to its mounting frame. A direct wire connection between the motor frame and the drive chassis minimizes interference in other equipment.

The encoder feedback cable must be a shielded cable. Connect the shield to TB1 terminal 1 on the control end. Standard installation requires a nine-conductor shielded cable (Belden™ part #9539 or equivalent). The colors of this cable correspond to the colors of the wires in the motor and on the connection diagram. You may interchange the Purple and White wires without ill effect.

The shield must be continuous from the motor to the control. Do NOT ground the shield at intermediate points. This applies to all junction boxes installed between motor and control.

DO NOT USE THE SHIELD OF THE ENCODER CABLE AS AN ACTIVE CONDUCTOR!

If you want to use the motor thermal protector in a 120 VAC circuit, run it in wiring separate from the cable. Use seven-conductor shielded cable. In this case, if the cable wire colors are different from the diagram, you need to check them carefully for proper connections.

REGENERATIVE RESISTORS

Regenerative motor controllers require a method of handling energy that is generated by the motor and returned to the drive. Traditionally, this has been handled by two methods: (1) using the power lines as a power sink by dumping excess energy back into the power source, and (2) dissipation as heat.

The first method was popular with DC drives, but it is becoming very unpopular because of the disruptive effect of the electrical noise in the power system.

The first method has been used by Brushless DC drives, inverters, and vector-type controls. In motor systems at larger horsepower, the dissipation means can get bulky and expensive. At horsepower in the range of the 1000AR series of drives, they are not a big problem.

Regenerative resistors are rated in terms of resistance and power.

The resistance of the bus loader resistors must allow enough current to flow from the bus through the resistor(s) to remove the energy at a rate faster than the motor can generate it. The bus voltage times the bus loader current must be greater than 150% of the motor's full power rating.

The power rating of the resistors depends on the duty cycle of the regeneration. **Powertec** uses four ratings for the GENESIS series of drives:

1. STOPPING DUTY = used to stop the motor once per minute = approximately 10% duty cycle.
2. EXTENDED DUTY = used to stop high inertia loads = approximately 25% duty cycle.
3. LIFTING DUTY = used on cranes and hoists and inclined conveyors = 50% duty cycle.
4. CONTINUOUS DUTY = 100% duty cycle.

The standard supplied with standard GENESIS drives is STOPPING DUTY.

Any duty cycle other than stopping duty **MUST BE EVALUATED BY A MECHANICAL ENGINEER**. The amount of regenerative power needed is a **MECHANICAL**, not an **ELECTRICAL**, calculation.

To avoid using many different resistors, standard resistor values have been adopted.

The standard resistor for 230 VAC drives is 25 ohms @ 420 W.

The standard resistor for 460 VAC drives is 70 ohms @ 420 W.

The standard resistor for 380 VAC drives is also 70 ohms @ 420 W.

One resistor is used in parallel for each 5 HP or portion thereof.

BUS LOADER RESISTOR TABLE - Standard Duty Resistors

Line Voltage <u>VAC</u>	Motor HP <u>HP</u>	Resistors <u># @ ohms</u>	Equivalent R <u>ohms</u>	Dissipation <u>watts</u>	Peak Amps <u>ADC</u>	Ave. Amps <u>ADC</u>
230	up to 5	1 @ 25	25.00	375	15.00	1.00
230	7.5	2 @ 25	12.50	750	30.00	1.50
230	10	2 @ 25	12.50	750	30.00	2.00
380	up to 5	1 @ 70	70.00	375	8.86	0.60
380	7.5	2 @ 70	35.00	750	17.72	0.90
380	10	2 @ 70	35.00	750	17.72	1.20
460	up to 5	1 @ 70	70.00	375	10.72	0.50
460	7.5	2 @ 70	35.00	750	21.45	0.75
460	10	2 @ 70	35.00	750	21.45	1.00
460	15	3 @ 70	23.33	1125	32.16	1.50

All resistors are connected in parallel.

HOW DO I ...

CONNECT THE REGENERATIVE RESISTORS TO THE MODEL 1000AR?

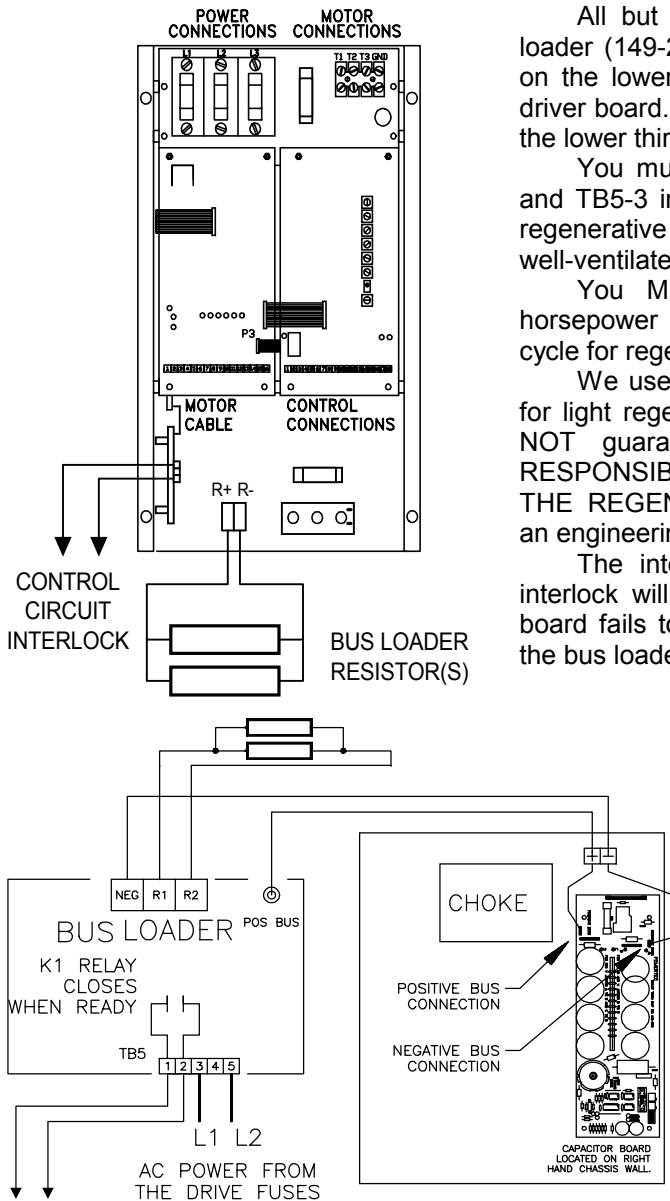

CONNECT K1 RELAY INTERLOCK IN EMERGENCY STOP CIRCUIT TO DETECT FUSE FAILURE OR BUS LOADER MALFUNCTION.

All but the largest Model 1000AR drives have the bus loader (149-201) built into the chassis. The bus loader mounts on the lower left-hand side panel and it plugs directly to the driver board. The power components for the bus loader are on the lower third of the chassis.

You must include the interlock between terminals TB5-1 and TB5-3 in the control circuits. You must locate the drive's regenerative resistors outside the enclosure in a clean, dry, well-ventilated area.

You MUST connect the regenerative resistors. The horsepower of the drive, the inertia of the load, and the duty cycle for regeneration determines the number of resistors

We use a standard 10% duty cycle for stopping duty and for light regenerative loads. The standard resistor package is NOT guaranteed to handle all situations. IT IS THE RESPONSIBILITY OF THE USER TO SPECIFY THE SIZE OF THE REGENERATIVE RESISTOR PACKAGE. If necessary, an engineering evaluation should be made.

The interlock is built into the Bus Loader board. The interlock will open if the bus loader fuse opens up or if the board fails to function. If the drive tries to regenerate without the bus loader operating, the drive will trip.

The separately mounted bus loader (149-101) should be mounted close to the drive. The resistors must be mounted in their own cage outside any enclosure. Mount the resistors in a clean, dry and well ventilated area away from personnel.

TB5 terminals 3 and 5 must be connected to the AC drive power. The drawing shows L1 and L2 connected, but any two of the three phases can be connected.

The resistors must be connected to the R1 and R2 terminals. All standard resistors are connected in parallel (see page 10 for resistor values).

Connect the interlock at TB5 terminals 1 and 2 into the control circuit (see page 15).

Connect the fuse input to the POS BUS connection on the Capacitor Board. Connect the NEG terminal to the NEG BUS connection on the Capacitor Board.

Operating the 1000AR drive without the Bus Board attached, or with the Bus Loader disabled, will result in the drive tripping. OverVoltage will occur as soon as regenerative operation is attempted. This could also result in damage to the drive.

CONTACTOR SPECIFICATIONS

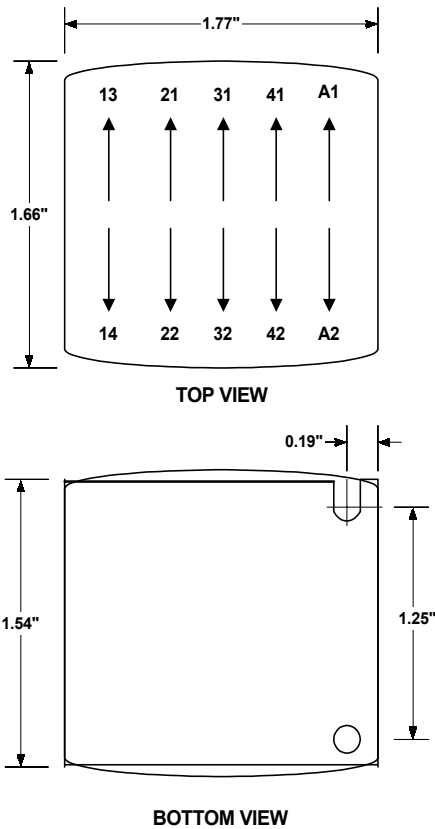

If you want to operate an Output or DB Contactor directly from the Model 1000AR, you must choose a coil that draws less than 50 milliamps DC.

The Output Contactor drawing on page 11 shows the connections for direct operation of the contactor (use the same connections for Dynamic Braking). The coil must be 48VDC and draw less than 50 ma DC (2.4 Watts). This is the most power available from the Model 1000AR drive's supplies.

To use a 115VAC or 230 VAC coil, you need a 156-012 Contactor Control board, as shown in the drawing on page 11. Use the same drawing for the Output Contactor. Maximum current for the Contactor Control board is 1 Amp at 230 VAC.

You need three normally open power poles and a normally open auxiliary for an Output Contactor. The contactor does not make or break with current in the power contacts. Choose the contact ratings only on the basis of carrying the current.

For Dynamic Braking, you need three normally closed power poles and a normally open auxiliary. The contacts make with current present, but they do not break current in the dynamic braking operation. Choose contacts accordingly.

The contactor outline sketched at left is from the SH-04 series by AEG Industries. The model used for the Output Contactor is part number SH-04.40 and the Dynamic Braking is SH-04.13. Contact ratings are 16 Amps.

DYNAMIC BRAKING RESISTORS

We choose DB resistors for their ability to absorb high inrush currents and to accept large amounts of power for short periods of time. Typical DB resistors can absorb ten times their power rating for up to five seconds. The resistors must then cool down to ambient temperature before they can dissipate their full rating again (usually a few minutes). It is possible to extend the ratings by about three times with power resistors by forced-air cooling.

You can derive an approximate value of dynamic braking resistor from the bus voltage and the full load current on the nameplate of the motor:

$$\text{Each Resistor Value} \sim \frac{\text{Bus Voltage} \times 0.47}{\text{Motor FLA}}$$

Three resistors (or groups of resistors) are necessary. The power rating of each should be:

$$\text{Power} > 0.02 \times (\text{Buss Voltage})^2 / (\text{Resistor Value})$$

These formulas are very general, and results will vary from motor to motor. For dynamic braking tailored to your application, consult **POWERTEC** Engineering.

MODEL 1000AR CONTROL CONNECTIONS

MOTOR THERMAL	STD: CONNECT FROM TB2-10 TO TB5-1**	Normally closed thermal switch in the motor. THE MOTOR THERMAL SWITCH MUST BE USED TO PROPERLY PROTECT THE MOTOR! When the switch opens, the drive must be shut off to prevent damage to the motor from overheating.
EMERGENCY STOP	+24VDC ON TB2-11 STD: N/C PB FROM TB2-11 TO TB5-3**	Voltage must be present to RUN or JOG. When removed, ENABLE REQUEST is blocked immediately (see page 29) and all control functions are disabled. Do not connect voltage to terminal with permanent jumper. In RAMP STOP mode, this is the only way to stop the drive.
RAMP STOP	+24VDC ON TB2-12 STD: N/C PB FROM TB2-11 TO TB2-12	Voltage must be present to maintain RUN mode after a momentary START is removed. When voltage is removed, the drive decelerates to zero speed at the DECEL rate and shuts off if RAMP STOP jumper JP2 is installed. Otherwise drive shuts off immediately and the motor coasts to a stop.
START / RUN	+24VDC ON TB2-13 STD: N/O PB FROM TB2-12 TO TB2-13	Voltage must be applied to initiate RUN mode. When it is removed, drive shuts off unless +24VDC is present at TB2-5. RUN LED turns on when +24VDC is applied to TB2-4. RUN LED turns off and RUN relay drops out when voltage is removed from both TB2-4 and TB2-5.
RUN CONTACT	TB2-7 AND TB2-8	Normally open dry contact closes when START is energized and opens when RUN relay drops out. The RUN contact does not open on a FAULT. The RUN contact does not close on JOG and opens in RAMP STOP mode.
ZERO SPEED	OUTPUT: TB2-1 COMMON: TB2-16	Open collector transistor output referenced to TB2-12. Rated at 50 mADC @ 50 VDC max. This output operates only in RUN, JOG, or RAMP STOP modes. The ZERO SPEED output turns on at about 10 RPM and off at about 5 RPM. The ZERO SPEED output shuts off if the ENABLE LED shuts off.
JOG	-24VDC ON TB2-14 STD: N/O PB FROM TB2-9 TO TB2-14	Voltage must be applied to initiate JOG mode. JOG mode will be maintained only as long as the voltage is present. When the voltage is removed, the drive will go to RAMP STOP mode if COAST TO STOP jumper JP2 is installed. Otherwise the drive shuts off and the motor coasts to a stop.
HOLD	-24VDC ON TB2-15 STD: N/O PB FROM TB2-9 TO TB2-15	When the voltage is applied, the output of the Voltage Controlled Oscillator is reduced to zero PPR. This causes the drive to decelerate to zero speed in current limit and hold there. When the voltage is removed, the drive accelerates back to set speed in current limit.
NOTICE: The drive is NOT OFF in the HOLD function.		
FAULT OUTPUT	OUTPUT COLLECTOR: TB1-12 EMITTER: TB1-13	Optically coupled transistor output (isolated). Rated at 50 mADC @ 50 VDC. Turns on when bus has achieved proper level. Output is off when any trip occurs.
ANALOG/ DIGITAL SWITCH	+24VDC ON TB1-10 REFERENCE TB1-9 TB1-9 IS NOT DRIVE COMMON	Apply voltage to switch to DIGITAL mode. TB1-10 and TB1-9 are electrically isolated from the board power supplies. The negative side of the +24VDC used for the input must be connected to TB1-9. External frequency must be applied to terminal 11. Terminal 9 is also common for this frequency.
** Note: TB5 is on the Bus Loader. The Small Bus Loader interlock is TB5-1 and TB5-3. The large Bus Loader interlock is TB5-1 and TB5-2.		

HOW DO I ...

CONNECT STANDARD CONTROL CIRCUITS?

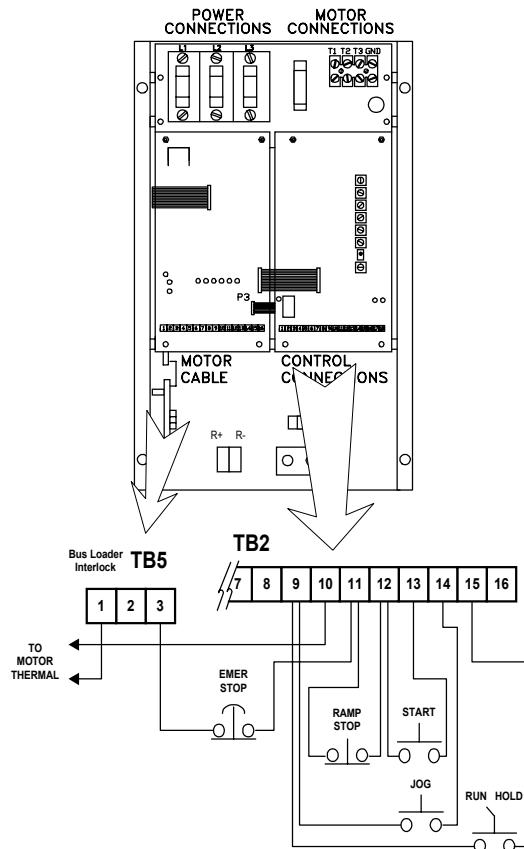

If you are using an output contactor or dynamic braking, go to page 19.

The table on the opposite page lists the functions of the Model 1000AR. The table lists the connections and descriptions of the control circuits. Read the descriptions of the operations of these circuits very carefully. There are differences between analog and digital modes.

The control circuits of Model 1000AR motor control operate on 48 VDC. This results from using the positive and negative 24 VDC supplies. Using 48VDC helps balance the load of relays and other devices on the power supplies.

The maximum current from each of the raw supplies is 50 milliamps. Due to this limitation, you must use an external supply when you use several external relays.

THE POWER SUPPLIES OF THE MODEL 1000AR SHOULD NOT BE USED FOR EXTERNAL EQUIPMENT! **Powertec** has an optional power supply (part # 127-101) available for 24VDC to power external circuits.

It is possible to operate control circuits with a variety of devices. Standard operator devices are O.K., but the current flow to these devices is very small. When locating pushbuttons more than 30 feet away from the motor control, consider using 120 VAC control circuits.

Install ESTOP buttons Do NOT place a jumper across the Emergency Stop terminals. Because the drive has a ramp to stop capability, this could set up an **UNSAFE** situation. IT IS STRONGLY RECOMMENDED THAT AN EMERGENCY STOP BUTTON (or an ESTOP relay) BE CONNECTED TO THE DRIVE! This should be of the MAINTAINED CONTACT TYPE.

The motor thermal must be used to PROPERLY protect the motor!

You can use a "two-wire" control by connecting a contact or switch between terminals 11 and 13 on TB2. Leave off the RAMP STOP and START buttons. This DOES NOT disable the RAMP STOP function. The only way to disable the RAMP STOP function is removing the RAMP STOP jumper.

The RAMP STOP function in the analog mode shorts the analog reference input to zero. This causes the motor to decelerate to zero speed before shut-down.

Note that the JOG function is disabled by the RUN function. If you activate the JOG input while the RUN mode is in operation, there will be no effect.

The HOLD function zeroes the speed reference to bring the motor to a stop and holds the drive at zero speed. THE DRIVE IS NOT OFF IN THE HOLD MODE! There is a potential for the motor to run, so the appropriate safety precautions should be taken.

TERMINAL DESCRIPTIONS - MODEL 1000AR**TB1 Current Controller Board (141-108)**

1	Dedicated Shields and Ground connection	
2	HS1 position encoder	
3	HS3 position encoder	
4	HS2 position encoder	
5	HS4 speed encoder	
6	HS5 speed encoder	
7	Encoder Common	for encoder ONLY
8	Encoder +5 VDC	for encoder ONLY
9	Isolated Common	for terminals 10 and 11
10	Auto/Manual Selection	+24 VDC for Digital Mode
11	External Frequency Input	+24 VDC Square Wave
12	Collector of FAULT transistor	
13	Emitter of FAULT transistor	
14	Drive Load output	-2VDC = 150%
15	Auxiliary Supply output	+15VDC for extra encoder
16	Power Supplies Common	

TB2 Speed Controller Board (147-101)

1	ON at zero speed (open collector)	30VDC 50 mA maximums
2	ON when enabled (open collector)	30VDC 50 mA maximums
3	Speed Output (open collector)	30VDC 50 mA maximums
4	-10VDC Reference Source	5 mA maximum
5	Speed Reference Input	-10VDC to +10VDC
6	+10VDC Reference Source	5 mA maximum
7	RUN output contact	N/O 125VAC
8	RUN output contact	N/O 1A Resistive
9	-24VDC supply	50 mA maximum
10	+24VDC supply	50 mA maximum
11	EMERGENCY STOP Input	+24VDC to activate
12	RAMP STOP Input	+24VDC to activate
13	RUN/START Input	+24VDC to activate
14	JOG Input	-24VDC to activate
15	HOLD Input	-24VDC to activate
16	Signal Common	

TB3 Capacitor Board (141-106)

1	Horsepower calibration resistor
2	No connection
3	Horsepower calibration resistor

TB5 Bus Loader (Integral unit connected to Driver board)

1	Bus loader Interlock	N/O 125VAC
2	No connection	
3	Bus loader Interlock	N/O 1A Resistive

HOW DO I ...**GET RUN, ZERO SPEED, FAULT AND ENABLE INFORMATION?**

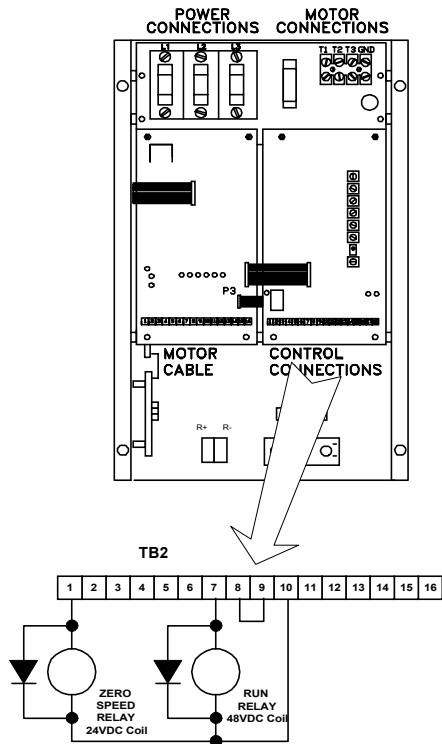

The RUN relay contact at TB2 terminals 7 and 8 is a dry contact rated at 1 Amp (Resistive load) at 125VAC. You may use it in an external circuit as long as the voltage does not exceed 125 VAC (limitation of the terminal strip).

You may use an auxiliary relay if you need more power, or if you need more contacts, as shown in the drawing at the left. You should use a 48VDC coil (highly recommended) since this reduces the burden on one supply. The diode is a general purpose type rated for at least 1 Amp at 100VDC PIV (1N4002 or equivalent).

The ZERO SPEED output at TB2 terminal 1 is an open collector NPN transistor, rated at 50 ma at 50 VDC. The ZERO SPEED transistor turns on at about 10 RPM and turns off at about 5.RPM

The transistor emitter is at drive common and it may interface directly with a PLC as a sinking input.

The output can operate a relay as shown in the top drawing on the left. The transistor returns to drive common, so it is not possible to use a 48VDC relay with the drive's supplies. If you use a 24VDC relay, the current must be as low as possible. The diode is a general purpose type.

The ZERO SPEED relay will chatter at very low speeds. You can overcome this with a latching circuit that releases at the first dropout of the zero speed relay.

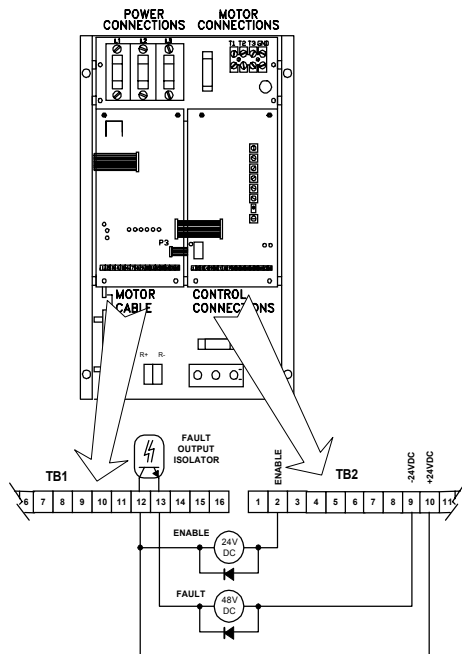

The FAULT output at TB1 terminals 12 and 13 is the output transistor of an optical coupler. The coupler's rating is 100VDC @ 50 ma.

Connect a FAULT relay with a 48VDC coil as shown in the bottom figure at left. The external FAULT relay energizes when the drive completes power-up and de-energizes when a fault occurs. The diode is a general purpose diode.

The Model 1000AR has an ENABLE output terminal at TB2 terminal 2. The ENABLE output is an open collector transistor that turns on when the drive is ready to accept a reference for speed input, whether in RUN or in JOG. You must use a 24VDC coil on the ENABLE output.

The ENABLE output shuts off if there is a trip or when the drive shuts off either on Emergency Stop or a non-ramp stop, or when the JOG input is released.

The internal RUN relay drops out on RAMP STOP. The ENABLE output remains energized throughout the RAMP STOP sequence. Use ENABLE for functions which must continue when the motor is running.

PLC INTERFACE

SINKING CONNECTION

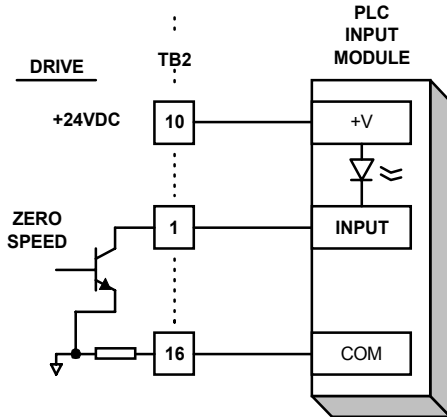

The interface of the Models 1000 and 1000A with a process controller is dependent upon the ability of the PC to handle the required signals.

Most of the signals are +24 VDC or 48 VDC (positive and negative 24 VDC supplies for control), or +10 VDC for speed. You may also use computer generated frequency signals for speed in the DIGITAL mode.

There are two types of input modules.

A "sinking" connection uses the Programmable Controller's own power, or an external source, and connects it (sinks it) to common level by the connected input device. The drawing on the left illustrates the method for using an open collector output to "sink" the input of a +24 VDC PC input module using an external supply from the drive.. When the transistor turns on, it turns on the input module.

SOURCING CONNECTION

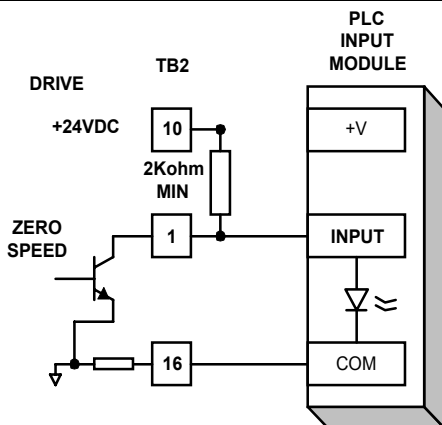

A "sourcing" connection turns on the PLC module by supplying power to it. The second figure shows a sourcing connection. Notice, however, the inverted sense, that is, when the transistor turns on, the input is not.

You can use the fault output with connections similar to those in the above figures. You can use a PLC input module, with the FAULT output of the control at TB1 terminals 12 and 13, to sense a FAULT in the drive. The bottom figure illustrates this.

FAULT MONITOR

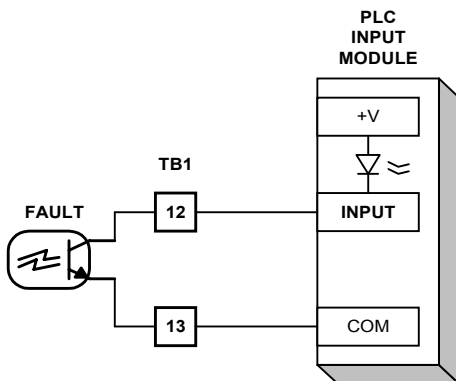

You need to keep in mind that the FAULT isolated output transistor is "ON" when there is no fault present.

You should accomplish all of the programmable controller operations of the standard control circuits of the Models 1000 series controls with relays. These circuits see 24VDC to ground, but they operate at 48VDC. RUN, JOG, STOP, and EMERGENCY STOP inputs operate on +24 VDC supplies. The circuitry, however, actually operates between positive and negative supplies, and it is difficult to make connections that do not involve both power supplies.

HOW DO I ...

CONNECT AN ANALOG SPEED REFERENCE?

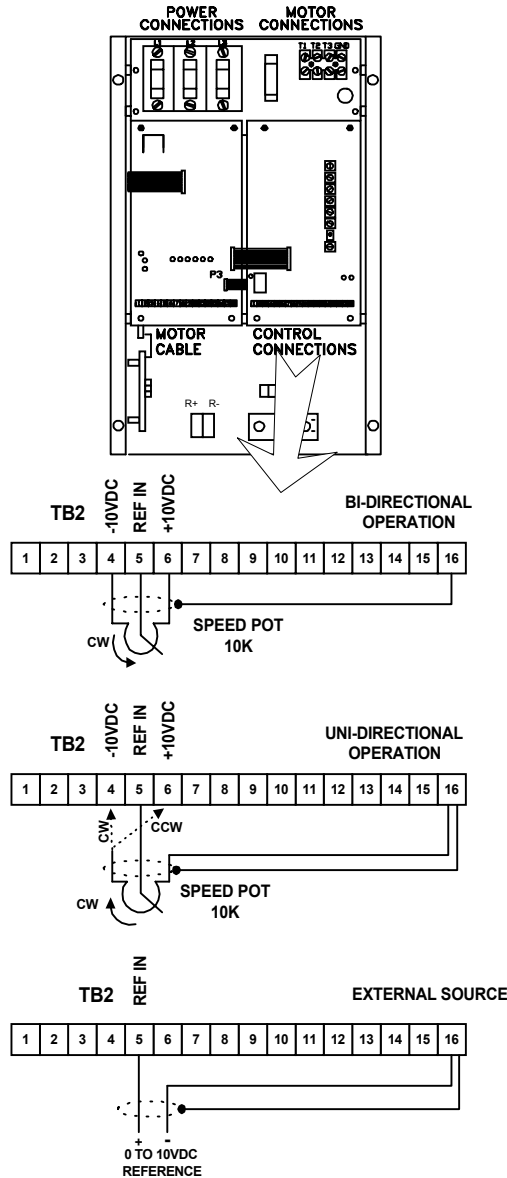

The analog speed reference for the Model 1000AR is -10 VDC to +10 VDC with the positive connection on TB2 terminal 5 and the common connection on TB2 terminal 16. Voltages less than -10 VDC become non-linear and voltages greater than 10 VDC become non-linear.

The input impedance is about 100K. Using a speed potentiometer with a resistance greater than 10 Kohms may result in non-linear operation of the speed pot.

There is a 10VDC source at TB2 terminal 4 and a +10VDC source at TB2 terminal 6. The supplies have a 10 ma limit.

There is no minimum speed pot on the 1000AR.

The input at TB2 terminal 5 is bi-polar. The direction of the motor is dependent on the polarity of the input reference. Connections are shown in the figure on the left for bi-directional operation (-10 VDC for full speed forward to +10VDC for full speed reverse. Zero VDC is zero speed.

Enclose the wires to a speed pot in a shielded cable, for noise reduction. Connect the shield only at the drive end, on TB2 terminal 16.

The reference voltage for the input does not have to come from the reference sources at TB2 terminals 4 and 6. You can introduce an external reference voltage between TB2 terminals 5 (+) and 16 (common). The speed of the motor varies as the external voltage varies. The direction of the motor changes when the polarity of the signal changes.

If you use an external "current source" speed control (such as a 4 to 20 ma signal), you must convert it to a voltage. Then you may introduce this voltage as a speed reference command to TB2 terminal 5 (+) and TB2 terminal 16 (-), as shown in the diagram.

When using a speed pot or an external voltage, it is not necessary to reduce the speed signal to zero before

starting the drive. Starting the drive with a speed input already present will not damage the drive, even at very high accel rates.

The Brushless DC drive operates over very wide speed ranges, so when you want the motor to stop with the drive in RUN mode, there must be ZERO VDC at the input. Voltages as low as 70 millivolts (0.070 VDC) will cause the motor to turn. Noise levels on the reference line can reach these values. You must be very careful about shielding and common mode voltages if you expect to operate with references of less than 0.5 VDC.

DIGITAL MODE NOTES

Since the Brushless DC motor control system is inherently digital, the performance in the digital mode of operation far exceeds the performance in the analog mode. In the digital mode the control and motor respond to a frequency signal fed to the control from an external source.

In the digital mode, we use the same digital control circuitry for the speed control as we do in the analog mode. The analog output of the accel/decel circuits drives a voltage-controlled-oscillator (VCO), which in turn feeds the digital circuitry. We bypass the VCO in digital mode and use an external reference frequency to control speed.

Activate the digital mode by applying a nominal +24 VDC voltage to TB1 terminal 10, positive with respect to TB1 terminal 9. There is also a jumper next to P2 on the Current Controller board (141-108) which, when placed in the AF position, switches the control into the digital mode without energizing terminal 10.

Either of these actions disconnects the control's internal VCO and looks for a frequency at TB1 terminal 11, which must be positive with respect to TB1 terminal 9. This frequency signal must meet certain specifications:

"ON" VOLTAGE: 18 VDC min, 30 VDC max
 "OFF" VOLTAGE: less than 1.5 VDC
 FREQUENCY: 2X desired RPM (250 frames or smaller)
 DUTY CYCLE: 25% min, 75% max
 MAXIMUM FREQ: 50 Kilohertz

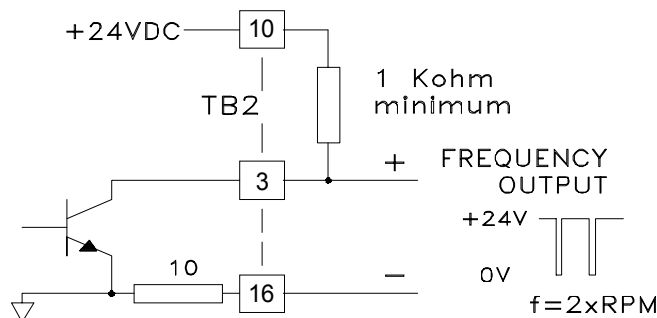

You can obtain the best tracking by "ramping" the frequency, that is, changing the frequency gradually. The motor accelerates in current limit if a frequency is present when the control starts.

The nature of the Brushless DC motor control is that the motor must return a pulse for each reference pulse supplied, except in current limit! You will lose pulses if the control goes into current limit, even for a brief time. So it is best to not change the external frequency so rapidly that the motor cannot respond without going into current limit.

In Digital Mode, you may select the direction of the motor rotation by the polarity of a voltage at TB2 terminal 5 (2Q/4Q jumper in the 4Q position), or with the FWD/REV jumper (2Q/4Q jumper in the 2Q position).

HOW DO I ...

CONNECT A DIGITAL SPEED REFERENCE?

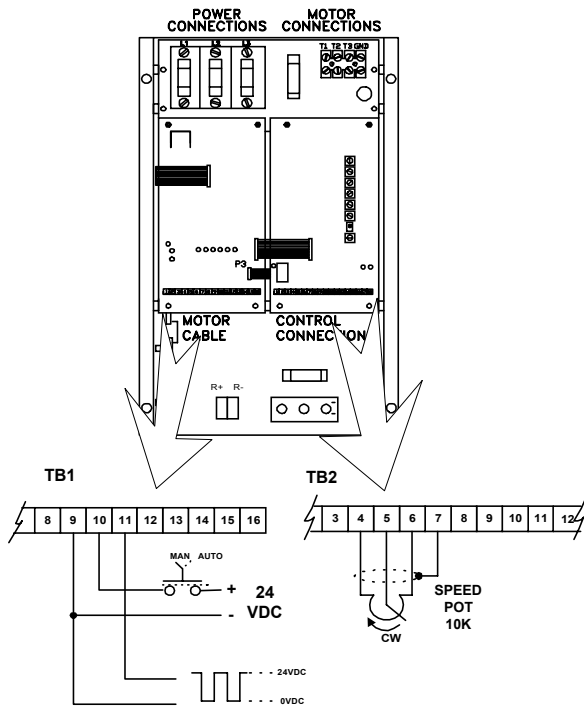

Apply +24VDC to TB1 terminal 10 (TB1-10) with respect to TB1-9 to operate the Model 1000 with a digital reference. Terminal 9 on TB1 is NOT the same as drive common. A jumper from TB2-10 will NOT switch to digital mode unless you connect TB1-9 to a drive common terminal (TB1-16).

With +24VDC on TB1-10, a pulse train at TB1-11 (with respect to TB1-9) commands the motor movement. On page 20, there is a list of recommended parameters for the pulse train.

You can also turn on digital mode by moving the "AF-N" jumper (JP1) on the Current Controller board to the AF position (the two left pins). After placing the jumper in the AF position, you do not have to energize terminal 10.

While in digital mode, Speed Controller board adjustments related to speed do not function, that is, SPEED POT, MIN SPD, MAX SPEED, ACCEL, DECEL, and JOG. The pulse train input governs the movement of the motor.

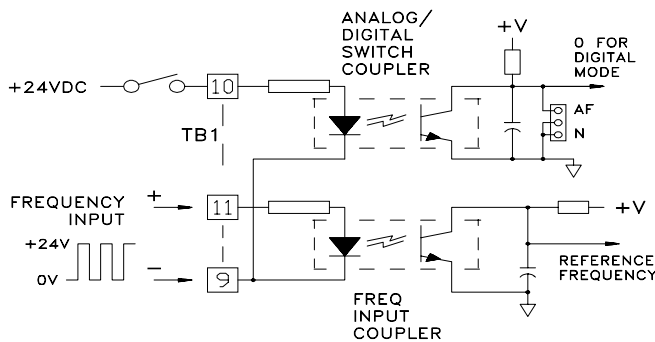

Almost all motors used with the Model 1000AR standard drives have 30 pulse per revolution quadrature encoders. This produces a 120 pulse per revolution (PPR) feedback. Each pulse put into the drive is a command to turn 3° in its mechanical rotation.

The pulse train input for a **GENESIS** drive may come from another **GENESIS** drive, since there is an output on TB2 (the figure below shows Model 1000 connections). Terminal 3 (TB2-3) is the collector of a transistor (TB2-16 is

common) which switches at twice the motor RPM. If you connect a resistor (at least 1 Kohm minimum) from TB2-10 (+24 VDC) to TB2-3, you generate a signal that can drive the input of another drive. Connect TB2-3 on the first control to TB1-11 on the second control, and connect TB2-16 on the first control to TB1-9 on the second. To switch to digital mode, connect TB2-10 on the first control to TB1-10 on the second.

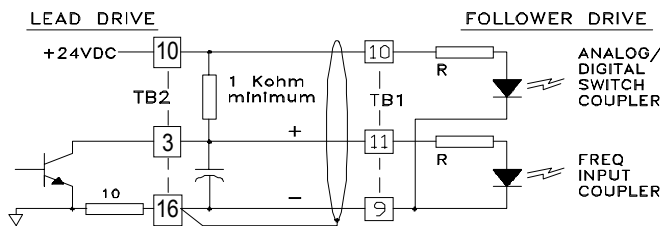

With this setup, the second motor will operate at exactly the same speed as the first, as long as you avoid current limit on the second control. If the first control encounters current limit, or changes speed for any other reason, the second one (the follower) will follow it in speed, even to zero speed.

ANALOG VERSUS DIGITAL OPERATION

The choice between ANALOG and DIGITAL operation comes down to performance.

In ANALOG mode, a voltage sets the speed of the motor. Due to analog component tolerances, the best accuracy you can expect is on the order of +/- 1%. It is typically 0.1% or better. The biggest problem with Brushless DC is not the following of an analog source. It is the obtaining of a clean and stable analog source to follow. Electrical noise can be a nasty problem, and you must use good shielding methods.

<u>ANALOG</u>	<u>Value</u>
Speed Regulation	0% from No Load to Full Load
Speed Accuracy	+/- 1% of Speed Reference
Speed Drift	+/- 1% of Speed Reference

In single motor operation, the motor does not have to follow a precise speed or a profile generated by another motor or other source. The ANALOG speed reference is

adequate in almost all cases. Changing load does not change the speed of the motor.

Coordinating the speed of two or more motors with analog methods requires some type of trimming device, such as a dancer or load cell. Analog tolerances and noise make exact coordination very hard.

In DIGITAL mode, the speed of the motor is proportional to the frequency of the pulse train presented at the TB1 terminals 11 and 9. Each pulse to the drive at these terminals will require a pulse from the motor. The EEPROM multiplier used in the Current Controller board determines the effect of the pulse from the motor. Analog tolerances do not disturb the system, nor will there be any temperature drift.

DIGITAL	Value
Speed Regulation	0% from No Load to Full Load
Speed Accuracy	1 Motor Feedback Pulse for each Pulse of Speed Reference
Speed Drift	+/- 1 Speed Reference Pulse

For single motor operation, use DIGITAL methods where precise speeds are important, that is, if you

really want to be able to set 1749 RPM and get that speed precisely. Motor load does not change the speed and the speed set by DIGITAL means has a drift of 1 Speed Reference pulse (less than 3° of motor shaft rotation).

Speed coordination of two or more motors requires DIGITAL means for systems that do not have a trimming device. Two motors connected by DIGITAL signals will track pulse for pulse.

Even though the motors may be made to operate together or in an exact ratio, there is a possibility that the mechanical system or the speed setting devices may not be identical. If this is the case, some type of trimming device may be necessary in a digital system. If the material does not stretch, this will become apparent in short order.

HOW DO I ...

CONNECT A DIGIMAX®?

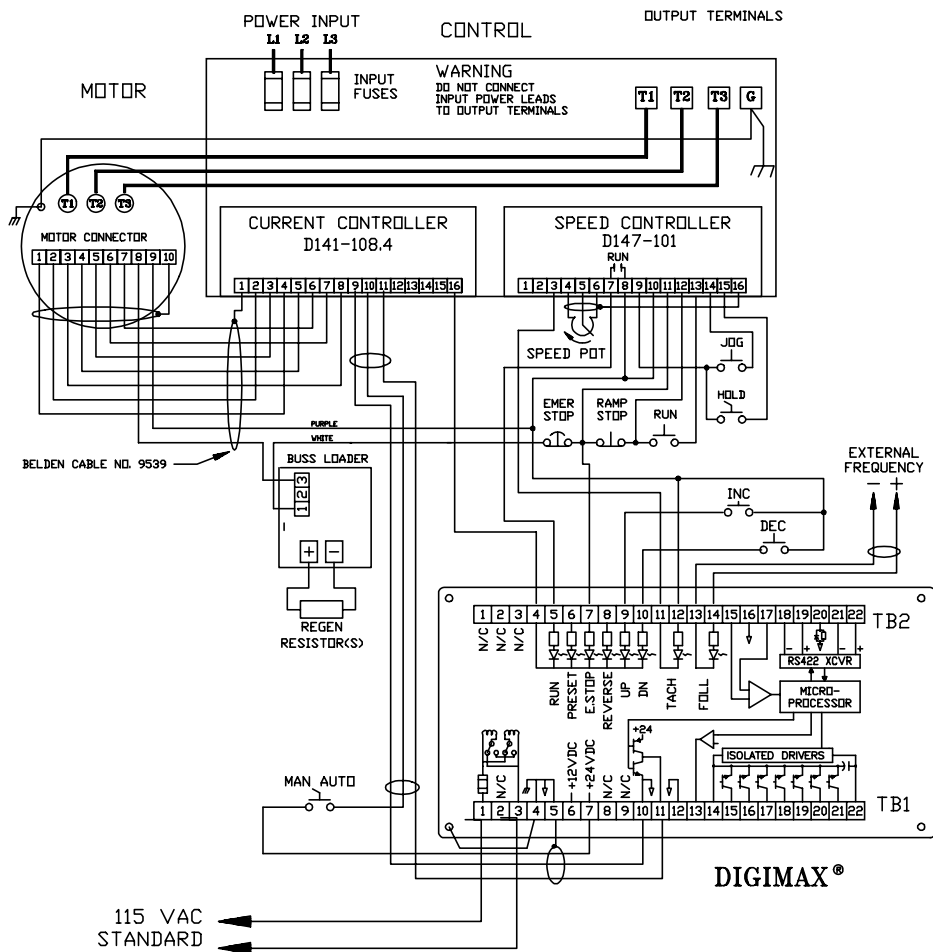

The DIGIMAX® is a crystal-based Speed or Ratio controller. It creates a train of pulses to command the movement of a motor when the drive is operating in digital speed mode.

A suitable train of pulses applied at TB1 terminal 11 (with respect to TB1-9) of the Model 1000 commands the drive to turn the motor 3° for each pulse. However, the drive's routine adjustments such as MIN SPEED, MAX SPEED, ACCEL, DECEL, and JOG SPEED are not functional. The DIGIMAX® supplies these functions.

The wiring diagram at left shows all the basic connections to the DIGIMAX. Not all of them are necessary for all installations. For instance, external frequency is only needed for slave mode.

The power, ground, and shield connections on DIGIMAX TB1 are necessary. The jumper from TB1-4 goes to a screw in the back plate.

The pulse train comes from DIGIMAX TB1 terminals 11(+) and 10(-). It is applied to the Model 1000AR TB1 terminals 11(+) and 9(-).

The MAN/AUTO switch may be left out. You can make a straight connection from DIGIMAX TB1-7 to Model 1000AR TB1-10. Even this connection may be left off if the Current Controller board jumper JP1 is in the AF position (see page 27).

The DIGIMAX control inputs are on TB2 terminals 5 through 10. These inputs require +24VDC. TB2 terminal 4 is the common connection for these isolated inputs. RUN (terminal 5) and ESTOP (terminal 7) are required for DIGIMAX operation. PRESET (terminal 6) is an optional second speed. The REVERSE input (terminal 8) must operate in conjunction with the drive's reverse, if it is used.

The EXTERNAL FREQUENCY input (TB2 terminals 13 and 14) is only used in the SLAVE mode. It is used when the DIGIMAX is to follow another pulse train from another DIGIMAX or drive.

The input at DIGIMAX TB2 terminals 15, 16, and 17 in an optional motor load reading signal.

For further information, refer to the DIGIMAX Installation and Operation Manual.

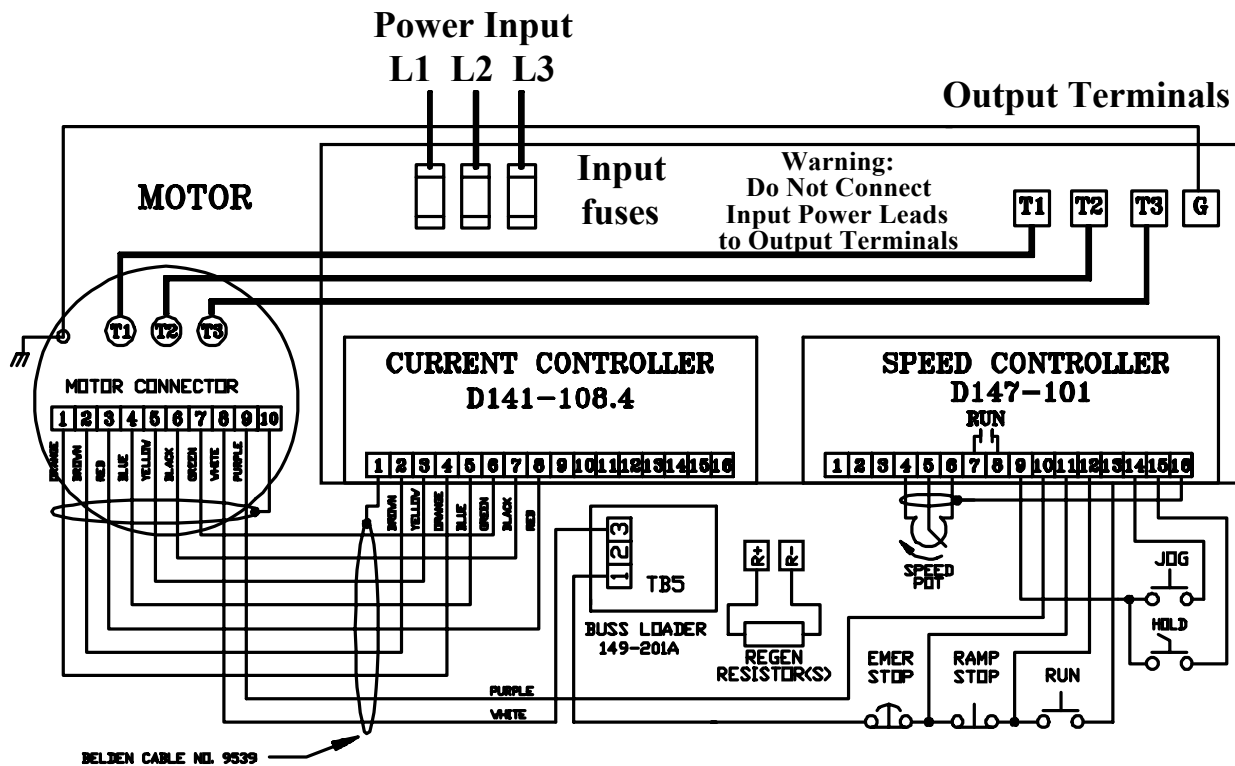

Model 1000AR Standard Connections

NOTICE:

ANY POWER EQUIPMENT SWITCHING HIGH VOLTAGES AT HIGH FREQUENCIES EMITS RADIO FREQUENCY INTERFERENCE (RFI) AND ELECTROMAGNETIC INTERFERENCE (EMI). THE MOTOR LEADS MUST BE RUN IN METALLIC CONDUIT TO PREVENT INTERFERENCE WITH OTHER EQUIPMENT. THIS CONDUIT MUST BE ALL IN ONE PIECE, IF POSSIBLE, AND THIS CONDUIT MUST BE SOLIDLY GROUNDED. ONLY THE MOTOR LEADS AND THE GROUND WIRE FROM THE CONTROL TO THE MOTOR SHOULD BE IN THIS CONDUIT.

INSTALLATION CHECKLIST

- Is the Model 1000AR securely mounted in a vertical position (fuses up) [page 5]?
- Is there a clear path for airflow through the base heatsink and through the chassis [page 5]?
- Is the temperature of the air surrounding the drive within specifications [page 5]?
- Is the AC power source for the drive of the proper voltage, frequency, and capacity [page 7]?
- Is the motor securely mounted and aligned [motor manual]?
- Is the drive and motor system properly grounded [pages 7 and 9] ?
- Are the motor leads connected in the proper order [page 9]?
- Is the cable from the motor to the drive properly connected [page 9]?
- Is the bus loader installed and properly connected [page 11]?
- Are the regen resistors properly installed and connected [page 11]?
- If an Output or Dynamic Braking Contactor is used, is it properly interlocked [page13]?
- If Dynamic Braking is used, are the resistors properly installed and wired [page13]?
- Is the motor thermal properly wired to the drive [pages 14 and 15]?
- Is the Emergency Stop button properly installed [pages 14 and 15]?
- Are other drive controls properly wired [pages 14 and 15]?
- Is the Speed Reference source properly wired in [page 19 or 21]?
- Is the motor mechanically safe to run (an unloaded motor is recommended) ?
- Is the machine safe to run and are all personnel clear ?

Proceed to the Start Up section.

BUS CONNECTIONS ARE ON THE CAPACITOR BOARD ON THE RIGHT SIDEWALL. BEHIND FRONT PANELS.

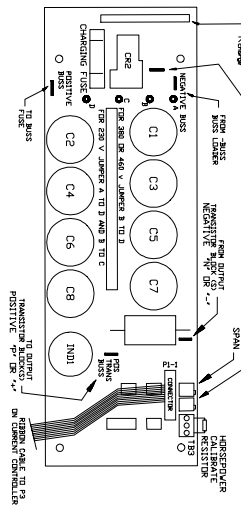
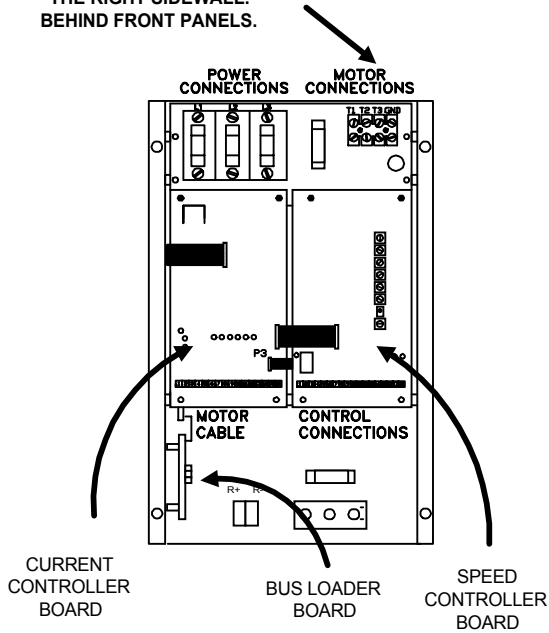

Capacitor Board Layout and Connections

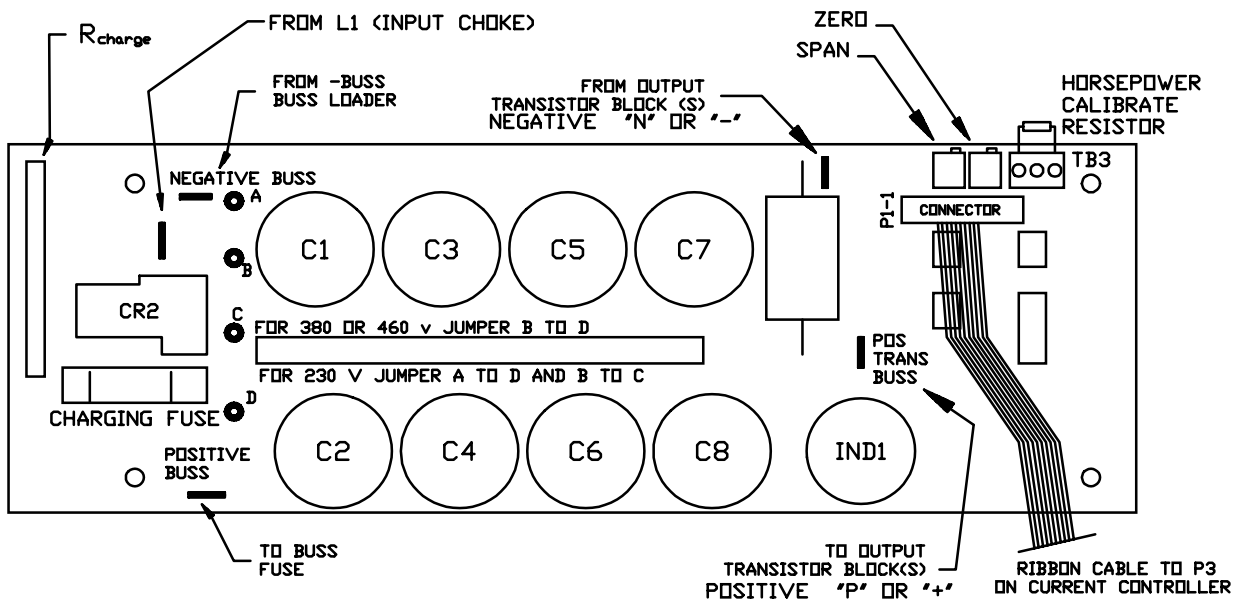

CURRENT CONTROLLER BOARD

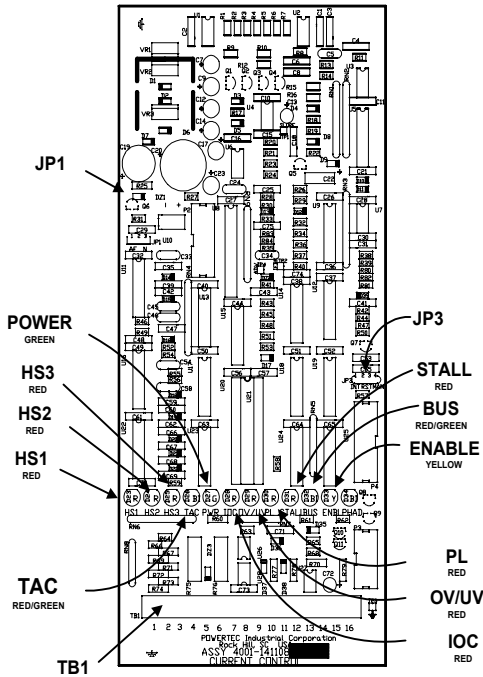

WHAT HAPPENS WHEN I ...

APPLY POWER TO THE MODEL 1000AR ?

When you apply the power to the Model 1000AR, the graph below demonstrates what happens to the drive's bus voltage.

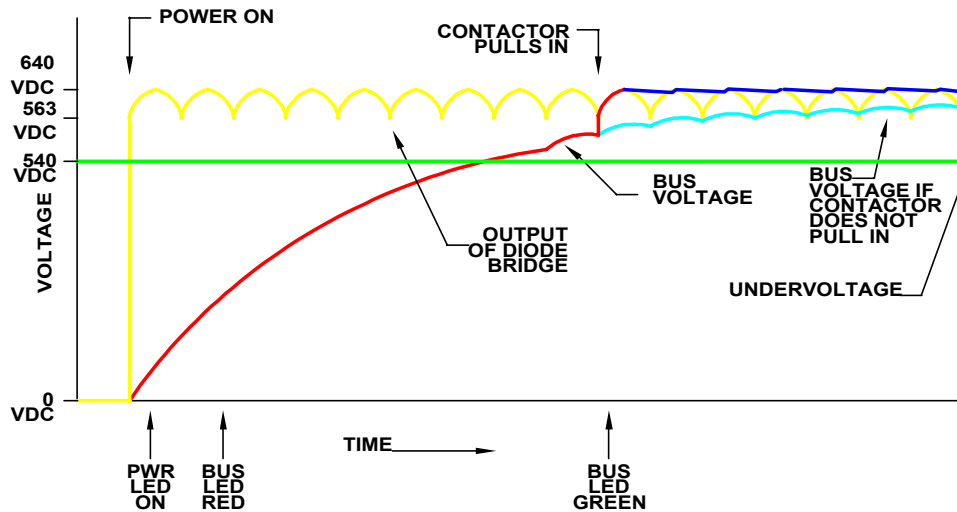

You can observe the bus voltage with a voltmeter connected to the POSITIVE BUS and NEGATIVE BUS terminals on the Capacitor Board. This board is located on the right sidewall of the drive behind the front panels (see page 26). The Bus terminals are near the top of the drive. BE CAREFUL. THESE TERMINALS MAY HAVE POTENTIALS UP TO 800VDC!!

There are LED indicators on the Current Controller board (see the layout on page 28). The action of some of these LED's is indicated in the graph above and on subsequent pages.

The POWER LED (it is GREEN in color) comes on as soon as the main power is turned on. This LED operates from the +24VDC raw power supply. If this LED does not come on, you should check the incoming power, main fuses and power transformer fuse.

While the bus is charging, the BUS LED lights up RED in color. When the bus reaches a level of approximately 35VDC below the nominal bus level, a contactor energizes to bypass the charging resistor. The BUS light then changes to GREEN in color. If the light does not change to GREEN within 30 seconds, turn off the input power and attach a meter to the bus terminals to monitor the bus voltage. See the troubleshooting section for assistance.

On the Current Controller board, there are three LED's labeled HS1, HS2, and HS3. These are the encoder position indicators. One or two of these indicators should be on. If none are on or if all three are on, there is a problem. Refer to the troubleshooting section. The TAC LED may be off or RED or GREEN. It is not important at this time.

The ENABLE LED should be off.

Once the bus has charged up and the BUS LED is GREEN, you may proceed to the next section.

A GREEN LED on the Bus Loader should be ON, but the RED LED on the bus loader must be OFF.

JUMPERS

CURRENT CONTROLLER BOARD 141-108

JP1 - "AF-N" Jumper - Used to decide whether or not the drive is permanently in the "DIGITAL" mode. This selection overrides the input at TB1 terminal 10. If JP1 is in the "AF" position, the drive is in the DIGITAL mode and TB1 terminal 10 has no effect. If JP1 is in the "N" position, you must apply +24VDC to TB1-terminal 10 to switch to DIGITAL mode.

2QOP - "RESET" Jumper - Used to trap faults when troubleshooting. Faults are normally reset by pressing the STOP button when the RESET jumper is in the INTERNAL (INT) position. When the RESET jumper is moved to the MAN (Manual) position, the faults do not reset by pushing the STOP button. The fault must be reset by moving the RESET jumper to the middle (RESET) position and then the jumper must be moved to either INT or MAN. The drive will not run with the jumper in the middle position.

SPEED CONTROLLER BOARD 147-101

JP1 - "10% REGEN" Jumper - When installed, allows Regen Current Limit up to 150%, when removed, limits to 10% of full load current.

2QOP - "2Q Operation" Jumper - Leave this jumper installed. Removing it disables the Current loop.

DIR/RL - "ACCEL/DECCEL Range" Jumper - Installing this jumper sets the ACCEL and DECCEL rates to 2 to 90 seconds (approximately). With this jumper removed, ACCEL/DECCEL rates are set for 50 ms to 2 seconds.

RAMP STOP - "RAMP STOP" Jumper - When this jumper is installed, the drive will decelerate at the DECCEL rate to zero speed and then shut off. If this jumper is removed, the drive shuts off as soon as the stop button is pressed.

2Q/4Q - "DIRECTION MODE" Jumper - The jumper marked 2Q/4Q actually controls the direction jumper's mode. In the 4Q position, the jumper sets the direction in Jog mode. This can be used to jog in the direction opposite the running direction. In the 2Q position, the motor rotation direction is determined by the position of the FWD/REV jumper. In Analog mode, the reference polarity must agree with the direction jumper or the drive will clamp the input reference to zero. In Digital mode, the FWD/REV jumper can be used to set the motor direction.

FWD/REV - "DIRECTION" Jumper - The direction jumper works with the 2Q/4Q jumper. See above.

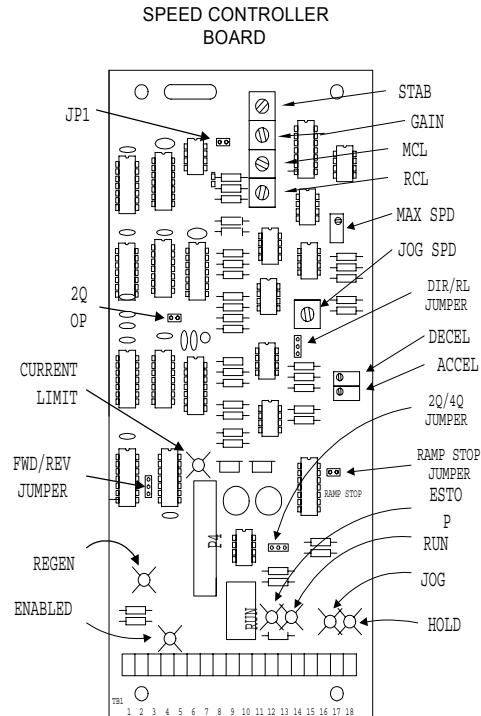

WHAT HAPPENS WHEN I ...

GIVE THE START COMMAND TO THE MODEL 1000 ?

Before starting the Model 1000AR drive, turn the Current Limit pots fully counter-clockwise, and the speed reference command input, analog or digital, should be set to zero.

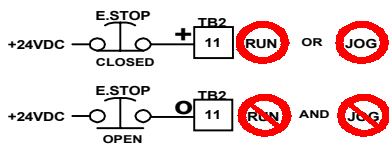

You must have +24VDC (all voltages relative to TB1 terminal 16) applied to TB2-11 (EStop input) before attempting to RUN or JOG. You must maintain +24VDC on TB2 -11 for as long as you want to run or jog.. Removing +24V from the Emergency Stop input will stop the drive regardless of whatever other inputs may be energized.

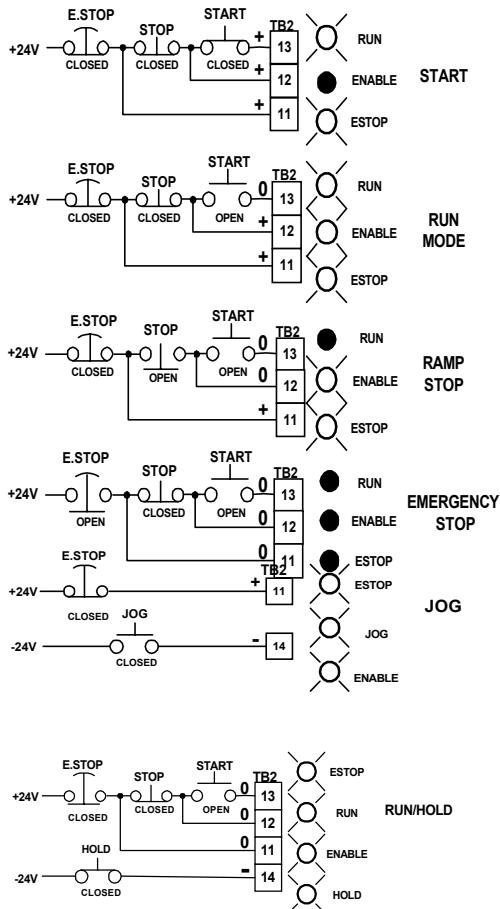

You must apply +24VDC to TB2 terminal 13 to start the drive. When you energize TB2-13, even if Emergency Stop circuit is NOT energized, the RUN LED will light and the normally open RUN contact between TB2-1 and TB2-2 closes. If Emergency Stop is closed, the drive stays in RUN mode as long as +24VDC is maintained on TB2 - 13.

If you use a momentary contact to energize the RUN input at TB2-13, then you must have +24VDC applied to TB2- 12 to continue running. If you do not have +24VDC applied to TB2-12, then the RUN LED goes off and the contact opens when you release the START button.

If you press the STOP button, or otherwise remove +24VDC from TB2-12, the drive will go to the ramp stop mode if the RAMP STOP jumper is installed. The motor will decelerate to a stop and the drive shuts off.

To shut off immediately, open the Emergency Stop button or otherwise remove +24VDC from TB2-11.

You start the drive in the JOG mode by applying -24 VDC (from TB2 terminal 9) to TB2 terminal 14. The JOG LED will light. The RUN LED will NOT light. The RUN contact will NOT close at TB2 terminals 7 and 8.

The JOG mode should be initiated from the STOPPED condition. The JOG mode is locked out in RUN mode.

Place the drive in HOLD mode by applying -24VDC (from TB2-9) to TB2 - 15. If the drive is stopped, HOLD will turn it on. HOLD clamps the VCO to zero speed. If the drive is running, it will decelerate to zero speed in current limit. As long as HOLD is on, the motor resists turning in either direction.

In JOG, HOLD, or RUN mode, an ENABLE REQUEST is generated, and the ENABLE LED's should light on the Current Controller and Speed Controller boards. Reasons why the LED's may not light:

1. The ENABLE LED will not light if the BUS LED is not GREEN;
2. The ENABLE LED will not light if the EMERGENCY STOP input is not energized;
3. The ENABLE LED will not light if any trip LED on the Current Controller board is lighted;
4. The ENABLE LED will not light if any of the ribbon cables is loose;
5. The ENABLE LED will not light if the RESET JUMPER is in the middle position.

Once the ENABLE LED is lit, turning the motor only requires the insertion of a speed reference.

LED INDICATORS**CURRENT CONTROLLER BOARD 141-108**

PWR	Power	Turns ON GREEN as soon as power is applied to the drive. Turns OFF when power is removed from the drive.
BUS	Bus Status	Turns ON RED as soon as power is applied to the drive Changes to GREEN when voltage across charging resistor drops below 35VDC. Changes back to RED if there is an OV/UV fault AND the drive is not enabled. Changes back to GREEN when OV/UV fault is cleared. Turns off when power is removed from the drive.
HS1	Hall Sensor 1	Turns on RED when SOUTH magnetic pole is over HS1 in encoder. Turns off when NORTH magnetic pole is over HS1 in encoder.
HS2	Hall Sensor 2	Turns on RED when SOUTH magnetic pole is over HS2 in encoder. Turns off when NORTH magnetic pole is over HS2 in encoder.
HS3	Hall Sensor 3	Turns on RED when SOUTH magnetic pole is over HS3 in encoder. Turns off when NORTH magnetic pole is over HS3 in encoder.
TAC	Hall Sensor 4 Hall Sensor 5	Turns on GREEN when SOUTH magnetic pole is over HS4 in encoder. Turns off RED when SOUTH magnetic pole is over HS5 in encoder. Turns on BOTH when SOUTH magnetic pole is over both HS4 and HS5. Turns off when NORTH magnetic poles are over both HS4 and HS5.
ENBL	Enable	Turns ON YELLOW when: <ol style="list-style-type: none"> 1. Drive is in RUN mode with no faults. 2. Drive is in JOG mode with no faults. 3. During RAMP STOP with no faults. Turns off when: <ol style="list-style-type: none"> 1. The UnderVoltage Timer times out. 2. There is an Undervoltage (UV) fault. 3. There is an OverVoltage (OV) fault. 4. There is an IOC fault. 5. There is a STALL fault. 6. RUN, JOG, HOLD, and RAMP STOP modes are all off.
STALL	Stall Fault	Turns ON RED if motor does not move 30° within specified time. Time is inversely proportional to motor current. Times out in 1.6 seconds at Current Limit (150% of full load). Will not time out if current is less than 40% of full load. Turns off when trips are reset.
PL	Power Loss	Turns ON RED if the +24 VDC raw supply drops below 18VDC. Turns ON RED if the +15VDC supply rises to within 3VDC of +24VDC. Turns off when trips are reset if the condition no longer exists.
OV/UV	Overvoltage Undervoltage	Turns ON RED in the following cases: <ol style="list-style-type: none"> 1. Bus Voltage is greater than 120% of nominal at any time. 2. Bus Voltage is less than 75% of nominal at any time. 3. Bus Voltage is below 85% of nominal for 80 mS or more. 4. The charging contactor is not energized.
IOC	Instantaneous OverCurrent	Turns off when trips are reset if the condition no longer exists. Turns ON RED if bus current to output transistors exceeds 300%. Turns off when trips are reset.
PHAD	Phase Advance	Indicates electronic shifting of encoder signals to achieve Constant Horsepower. GREEN indicates no phase advance. ORANGE indicates 18° of phase advance timing. RED indicates 30° of phase advance timing.

WHAT HAPPENS WHEN I ...

GIVE THE SPEED COMMAND TO THE MODEL 1000AR ?

Once the drive is in RUN mode, the application of the speed reference should cause the motor to turn. At this point:

- the PWR and BUS LED's on the Current Controller board should be GREEN;
- one or two of the HS1, HS2, and HS3 LED's should be on,
- the ENABLE LED should be ON on both Speed Controller and Current Controller.
- the ESTOP and RUN LED's on the Speed Controller board should be ON,
- the TAC LED on the Current Controller may be OFF, RED or GREEN, depending on the position of the motor.
 - the ILIMIT LED may be on if the Motoring Current Limit (MCL) pot is fully counter-clockwise.

If the above conditions do not exist, see the Troubleshooting section.

There are several ways to apply a reference:

1. For an analog speed reference, a speed pot or an external voltage, see page 25;
2. For a digital speed reference, see page 27 (Read the notes on page 26).

When the speed reference is increased from zero, the motor should turn. If the current limit LED turns on, check for the following:

1. If the motor is not turning, turn the Motoring Current Limit pot (MCL) clockwise to see if the motor will turn and the Current Limit LED turns OFF. If the pot is already more clockwise than its mid-point, turn it all the way counter-clockwise to protect the motor and drive.
2. If the Current Limit pot is fully counterclockwise, and the motor is not turning, turn the pot slowly clockwise to see if the motor will turn. If the motor turns, leave the Current Limit pot where it is when the motor begins to turn.
3. If the motor does not turn when the Current Limit pot is increased, do not turn the Current Limit pot higher than 50% of its rotation. Shut the drive off and check the connections between the drive and the motor. It is quite common that these connections are mixed up.

When the speed reference is increased, if the motor does not turn, but the Current Limit LED does NOT turn ON, check the following:

1. Make sure the RUN and both ENABLE LED's are ON;
2. Make sure a reference is being properly applied:
 - For an analog reference, a voltage between 0 VDC and +10V must be present at TB2-4 with respect to TB2-16(common). The AF/N jumper (JP1) on the Current Controller board must be in the "N" position and there must be 0 VDC between terminals 9 and 10 on TB1.
 - For a digital reference, there must be a suitable pulse train between terminals 11 and 9 on TB1 (see page 26). There must be 24VDC between TB1-10 (+) and TB1-9(-) OR the "AF/N" jumper (JP1) on the Current Controller must be in the "AF" position.

When the motor begins to turn, the HS1, HS2, and HS3 LED's on the Current Controller board will begin to flash on and off. These indicate rotation of the motor by turning on when the encoder magnets pass over the sensors. When the motor is turning rapidly, it will appear as though all three of the HS1, HS2, and HS3 LED's are on at the same time.

When the motor begins to turn, the TAC LED will begin to flash alternately RED and GREEN, then appear to be ORANGE as the motor turns faster.

Check the speed of the motor at the 10%, 25%, 50% and 100% points of the speed reference.

LED INDICATORS**SPEED CONTROLLER BOARD 141-107**

RUN	RUN mode	Turns ON GREEN when +24VDC is applied to TB2 terminal 13. Stays ON GREEN as long as +24VDC is applied to TB2-12 or TB2-13. Turns off when + 24VDC is removed from BOTH TB2-12 and TB2-13.
CURRENT LIMIT	Current Limit	Turns on GREEN when speed demand cannot be satisfied. One cause is current limit, which is adjustable from 0% to 150% of full load motor current. Another cause is when the speed required is too great for that load and bus voltage. Turns on RED when drive is in regenerative current limit, adjustable from 0% to 150% of full load. Turns off when above conditions cease to exist.
ENABLED	Enable	Turns ON YELLOW when: <ol style="list-style-type: none"> 1. Drive is in RUN mode with no faults. 2. Drive is in JOG mode with no faults. 3. During RAMP STOP with no faults. Turns off when: <ol style="list-style-type: none"> 1. The UnderVoltage Timer times out. 2. There is an Undervoltage (UV) fault. 3. There is an OverVoltage (OV) fault. 4. There is an IOC fault. 5. There is a STALL fault. 6. RUN, JOG, HOLD, and RAMP STOP modes are all off.
REGEN	Regen Mode	Turns ON RED when motor speed exceeds reference speed at any time. This may occur during stopping if the decel ramp time is less than the natural coasting time of the motor/load, or during running if the motor is "overhauled". Turns OFF when motor is at or below the reference speed.
ESTP	EStop Input	Turns ON GREEN when +24VDC is applied to TB2 terminal 11. Stays ON GREEN as long as +24VDC is applied to TB2-11. Turns off when + 24VDC is removed from TB2-11.
JOG	Jog Input	Turns ON GREEN when -24VDC is applied to TB2 terminal 14. Stays ON GREEN as long as -24VDC is applied to TB2-14. Turns off when +-24VDC is removed from TB2-14.
HOLD	Hold Input	Turns ON GREEN when -24VDC is applied to TB2 terminal 15. Stays ON GREEN as long as -24VDC is applied to TB2-15. Turns off when +-24VDC is removed from TB2-15.

WHAT HAPPENS WHEN I ...

SLOW DOWN OR OVERHAUL THE MODEL 1000AR ?

Since the Model 1000AR is a regenerative drive (see page 3), the motor does not coast when the speed reference is reduced. The deceleration ramp is enforced by removing energy from the motor. This is accomplished by treating the motor as a generator and applying a load to it.

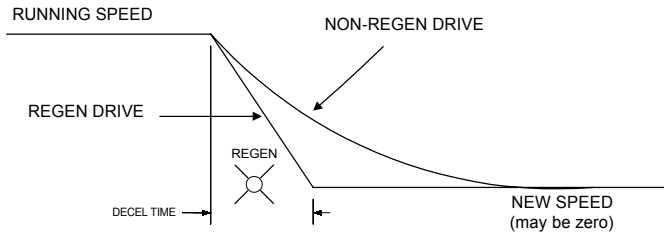

A non-regenerative drive coasts when the motor speed exceeds the commanded speed. The drive cannot force the motor to slow down. The non-regenerative drive will enforce the deceleration ramp time ONLY if the decel ramp time is greater than the natural coast time of the motor and load.

The regenerative drive (Model 1000AR) can enforce the decel ramp time at any regenerative load up to its Regenerative Current Limit (RCL) setting. If the inertia of the load is greater than can be slowed by the motor at regen current limit, or if the motor is being overhauled by another motor, the drive will continue to apply the current limited value of torque, but the drive will lose speed control. The motor and load will then slow down according to a modified coast time curve.

When you started up, you probably turned the RCL pot on the Speed Controller board down to the fully counter-clockwise position. The first time you turn down the speed pot, you should see a RED REGEN LED and a RED CURRENT LIMIT LED, but the motor may appear to be coasting. Turn the RCL pot clockwise to about 50% and bring the motor up to a high speed again.

Now, when you turn the speed pot down (it does not need to be zero; it can be any new, lower speed), the REGEN LED should light, but the CURRENT LIMIT LED may or may not come on. If the coast time is much greater than the decel time, the drive may reach current limit. Whether or not current limit will be reached can be predicted, but you need to know all the drive and motor data and all of the inertias involved in the system to do so. The maximum (CW) setting of the RCL is equivalent to 150% of full load.

You should also see a RED LED on the bus loader flicker to show it is operating and the regenerative resistors will get warm (for small or quick changes in speed) or hot (for longer regenerative intervals).

Since the regenerative mode is active only when the motor speed exceeds the commanded speed, the REGEN LED will be on only during the deceleration period. Once the motor gets to the new speed, regen shuts off and the drive returns to normal operation. If you are reversing the direction of the motor, the REGEN LED will only stay on until the motor stops.

If the motor speed is being increased by an outside force pulling on it (overhauling load), the REGEN LED will come on and stay on. The drive will attempt to hold the commanded speed by regenerating, up to a maximum of its RCL setting. In any case of an overhauling load, you must be careful not to exceed the rated capacity of the regenerative resistors.

If continuous regeneration is expected, and the overhauling load is caused by another motor, you may want to consider using a "common bus" configuration. A common bus configuration requires another BLDC drive which is ALWAYS in motoring mode while the regenerative unit is regenerating. This is the case if the common bus motoring motor is doing the overhauling which is causing the regeneration of the common bus regenerating motor.

ADJUSTMENTS

CCW = Counter-ClockWise position

CW = ClockWise position

MAX SPD	Maximum Speed	<p>ANALOG MODE only. Not an absolute speed limit. Calibration to reference. At CCW, with 10VDC input, generates a VCO frequency of 1200 Hertz. At CW, with 10VDC input, generates VCO frequency of 10 Kilohertz.</p>
JOG SPD	Jog Speed	<p>ANALOG MODE only. Sets speed during JOG mode. CCW is zero Jog Speed. CW is a jog speed of about 30% of full speed. Direction is set by jumper (see page 34).</p>
ACCEL	Acceleration time	<p>ANALOG MODE only. Sets amount of time to change from zero speed to full speed. With JP2in the R/L position, CCW is about 20 seconds. With JP2in the DIR position, CCW is about 0.05 seconds. With JP2in the R/L position, CW is about 0.5 seconds. With JP2in the DIR position, CCW is about 0.05 seconds.</p>
DECEL	Acceleration time	<p>ANALOG MODE only. Sets amount of time to change from full speed to zero speed. With JP2in the R/L position, CCW is about 20 seconds. With JP2in the DIR position, CCW is about 0.05 seconds. With JP2in the R/L position, CW is about 0.5 seconds. With JP2in the DIR position, CCW is about 0.05 seconds.</p>
GAIN	Gain adjust	<p>ANALOG and DIGITAL modes. Sets the stiffness of the motor shaft. Zero position is where the shaft should be at any point in time. Motor amps is proportional to offset of the shaft from the zero position. Stiffness is motor amps per degree of shaft offset from zero position. CCW is about 0.56% of full load current per degree of offset. CW is about 5.6% of full load current per degree of offset. Normal Gain setting is between CCW and 50% of rotation.</p>
STAB	Stability adjust	<p>ANALOG and DIGITAL modes. Sets the stability of the motor under load. CCW makes the drive more sluggish. CW makes the drive more sensitive. Normal setting is at about mid-range (50%) of pot rotation.</p>
MCL	Current Limit Motoring	<p>ANALOG and DIGITAL modes. Sets the maximum motoring current to the motor in percent of full load. This adjustment depends on the HP calibration resistor on TB3-1 and TB3-3. CCW is zero percent, or zero current. CW is maximum current limit, or about 150% of full load. In normal operation, CLIM is set to 150% (CW).</p>
RCL	Current Limit Regeneration	<p>ANALOG and DIGITAL modes. Sets the maximum regenerative current to the motor in percent of full load. This adjustment depends on the HP calibration resistor on TB3-1 and TB3-3. CCW is zero percent, or zero current. CW is maximum current limit, or about 150% of full load. In normal operation, CLIM is set to 150% (CW).</p>

WHAT HAPPENS WHEN I ...**MAKE AN ADJUSTMENT ON THE MODEL 1000AR ?**

Once the motor is running, it may be necessary to make adjustments to produce the desired results.

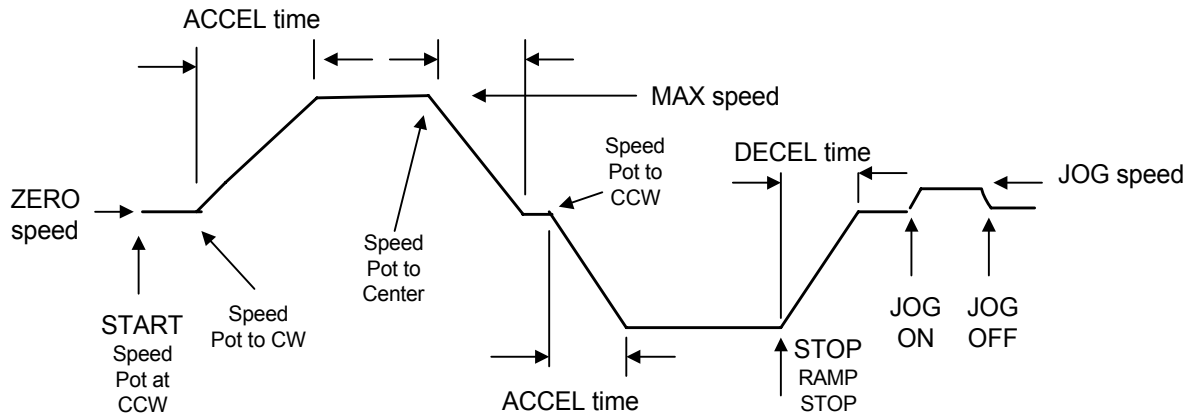

The speed pot may be connected for bi-polar reference input. The CW end of the pot should be connected to +10VDC (TB2-6), the CCW end to -10VDC (TB2-4), and the wiper to TB2-5.

If the speed pot is turned to 100% clockwise (CW), or the speed reference is otherwise increased to +10VDC at TB2 terminal 5, the motor will accelerate to the maximum speed at the ACCEL rate.. You may use the MAX on the Speed Controller to adjust maximum speed of the motor. Actually, MAX will affect the speed at any reference. The MAX adjustment is not an absolute limit. It is a calibration to the reference.

If you then turn the speed pot to the center (0.0 VDC), the motor decelerates to a stop at the DECEL rate. If the input is not exactly 0.0 VDC, the motor may turn slowly in one direction or the other.

Turning the speed pot to the CCW end causes the motor to accelerate to the MAX speed in the other direction at the ACCEL rate.

The amount of time it takes the motor to change from zero speed to maximum speed is adjustable with the ACCEL pot on the Speed Controller. The range of time depends on how JP2 is installed. With JP2 in the R/L position, the time for acceleration is adjustable from about 0.5 seconds (ACCEL pot fully CCW) to about 20 seconds (ACCEL POT fully CW). With JP2 in the DIR position, the time is not adjustable.

The ACCEL time is the time it takes the ramp circuit to change the speed reference from zero to full speed. The motor may not accelerate in the same amount of time if it is limited by inertia or load, in which case the motor will accelerate in current limit.

When the STOP button is pressed at full speed, if the COAST TO STOP jumper is removed, the drive will shut off and the motor will coast to a stop. The time it takes the motor to stop is called the "coast time". This time is not controlled unless Dynamic Braking is installed.

If the STOP button is pressed and the COAST TO STOP jumper is installed, RAMP STOP mode is initiated. The speed reference input is clamped to zero after the input at TB2 terminal 10 and the drive ramps the speed to zero. The drive then shuts off.

The amount of time allowed for the deceleration is adjustable with the DECEL pot on the Speed Controller board. This time has the same ranges as the ACCEL pot.

The Models 1000AR is a regenerative drive. When the RAMP STOP mode is in operation, or if the speed pot is turned to 0% while running at full speed, the DECEL time will be effective. When the motor gets to zero speed, the drive shuts off.

JOG speed is adjustable with the JOG pot on the Speed Controller board. JOG speed is affected by the MAX speed adjustment, but JOG speed is not affected by the MAX pot, the ACCEL pot, or the DECEL pot. JOG accelerates in current limit.

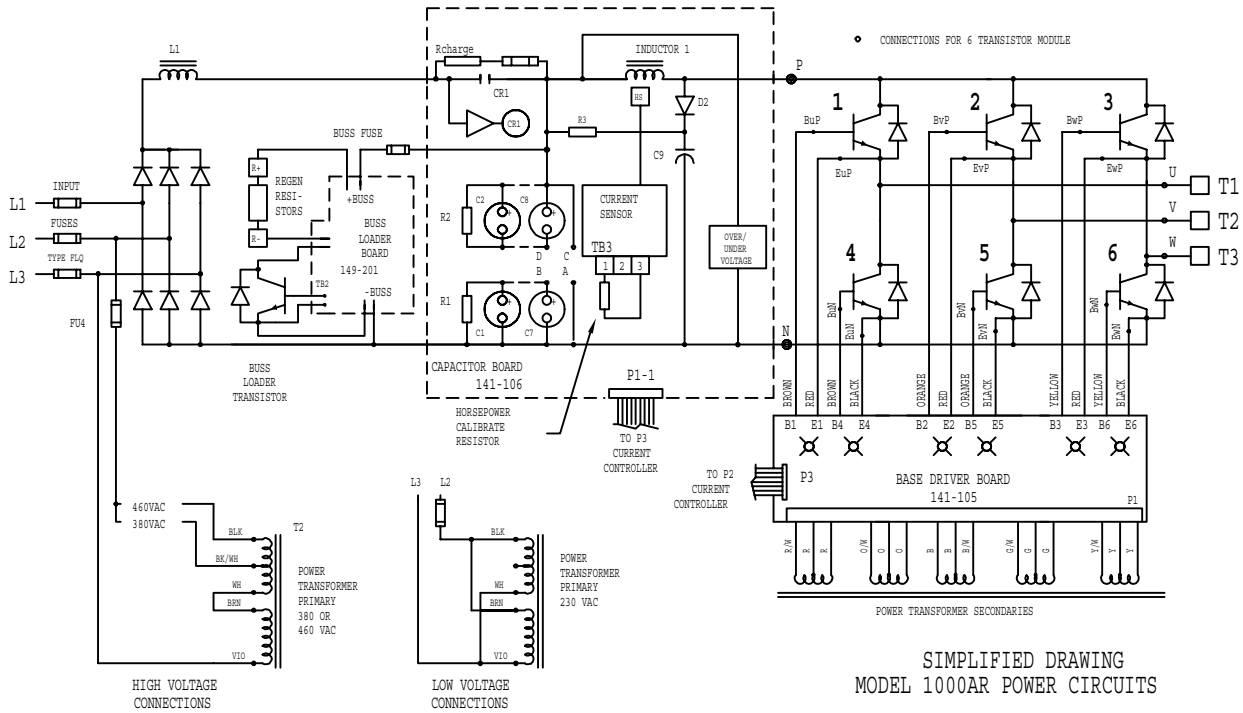

SIMPLIFIED DRAWING
MODEL 1000AR POWER CIRCUITS

TYPICAL DIODE BRIDGE CONFIGURATIONS

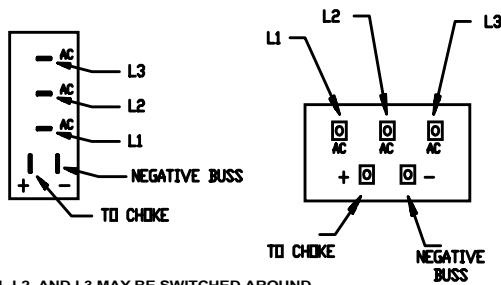

L1, L2, AND L3 MAY BE SWITCHED AROUND AMONG THEMSELVES WITHOUT ILL EFFECT

TYPICAL TRANSISTOR MODULE CONFIGURATIONS

6 TRANSISTOR MODULE

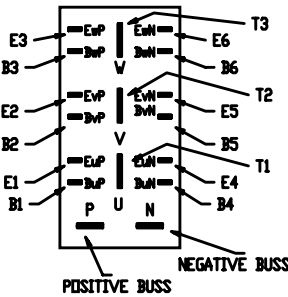

2 TRANSISTOR MODULE

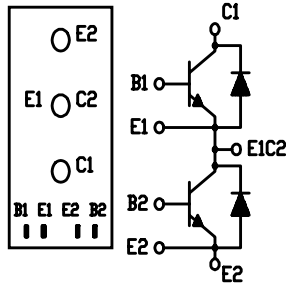

230 VAC
BUSS LOADER TRANSISTOR
PHYSICAL ELECTRICAL

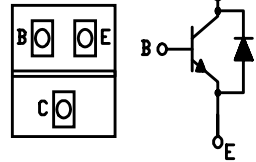

380/460 VAC
BUSS LOADER TRANSISTOR
PHYSICAL ELECTRICAL

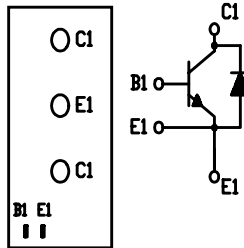

TROUBLESHOOTING THE MODEL 1000AR DRIVE

Troubleshooting of the Model 1000AR drive should only be attempted by personnel experienced in working on high-voltage, high power equipment.

Equipment Necessary for Troubleshooting :

1. Safety Glasses
2. A Volt-Ohm-Milliammeter, preferably digital, with:
 - A DC Voltage scale of 1000VDC minimum
 - An AC True-RMS Voltage scale of 1000VAC minimum
 - A fuse-protected ohmmeter with as low a scale as possible
 - A frequency reading capability, if possible
 - A plug-in attachment to read AC and DC current, if possible
 - Meter leads insulated for 1500 VDC
3. A True RMS clamp on ammeter for AC current, or DC current, or both
4. An oscilloscope is handy if the person using it knows how to use it well.
5. Other equipment may be required for some configurations.
6. A Megger is useful for checking motor integrity and wiring insulation.

Spare Parts are Necessary to do On-Site Repairs Quickly and Efficiently.

Some or all of the following parts may be required for fast on-site repair.
Listed in approximate order of importance.

Item Description	Part Designation	Part Number	Spares Quantity
Input Fuses	FU1, FU2, and FU3	* HP *	10
Transformer Fuse	FU4	FLQ-8/10	5
Capacitor Board		141-206	1
Output Transistor Module		* HP *	1
Driver Board		141-105	1
Current Controller Board		141-108	1
Input Diode Module	RECT1	* HP *	1
Power Transformer	T1	141-004	1
Speed Controller Board		147-101	1
Input Choke	L1	141-005	1
Bus Loader		149-201	1
Bus Loader Resistor(s)		50 ohm	1
Bus Loader Fuse		* HP *	1

* HP * means horsepower and/or voltage dependent.

Consult your Distributor for spare parts pricing and delivery.

A Word About The Troubleshooting Charts

Troubleshooting charts cannot solve every problem!

Troubleshooting charts are a useful tool in tracing simple problems down to the board or major component level. Follow the troubleshooting chart as far as you can until the problem is resolved or you reach a dead end.

If you find yourself coming back to the same point in the troubleshooting chart several times, call the factory and obtain the help of a trained technician. Let him know what point you keep coming to in the chart. This will help us to improve the troubleshooting chart in the future.

TRANSISTOR MODULE STATIC TEST

- Equipment needed:** A **Digital Multi-Meter (DMM)** with a diode scale is preferred. You should have a RED lead in the positive (+) input and a BLACK lead in the negative (-) input.
- Preparation:** Different meters give different readings on diode tests. **KNOW YOUR METER !!** Some meters read backwards due to battery polarity. Test YOUR meter on a known good diode bridge before performing tests so that you know how your meter will act.
- Refer to page 32 for the drive power schematic and semi-conductor diagrams.
- Precautions:** If the transistor module is to be tested in circuit, make sure power has been off long enough for the capacitor banks to completely discharge.
- Procedure:** The procedure is the same for in circuit or out of circuit testing. If a component tests bad in circuit, it must be tested again after it is removed because of the possibility of alternate paths when the component is in circuit.

SIX TRANSISTOR MODULE

RED LEAD	BLACK LEAD	GOOD	BAD
P	N	open	short
N	P	0.3 to 2.0	short or open
N	U	0.3 to 0.7	short or open
N	V	0.3 to 0.7	short or open
N	W	0.3 to 0.7	short or open
U	P	0.3 to 0.7	short or open
V	P	0.3 to 0.7	short or open
W	P	0.3 to 0.7	short or open
P	B1	open	short
P	B2	open	short
P	B3	open	short
U	B4	open	short
V	B5	open	short
W	B6	open	short
B1	U	0.3 to 500	short or open
B2	V	0.3 to 500	short or open
B3	W	0.3 to 500	short or open
B4	N	0.3 to 500	short or open
B5	N	0.3 to 500	short or open
B6	N	0.3 to 500	short or open

TWO TRANSISTOR MODULE

RED LEAD	BLACK LEAD	GOOD	BAD
C1	E2	open	short
E2	C1	0.3 to 2.0	short or open
E2	E1C2	0.3 to 0.7	short or open
E1C2	C1	0.3 to 0.7	short or open
C1	B1	open	short
E1C2	B2	open	short
B1	E1C2	0.3 to 500	short or open
B2	C2	0.3 to 500	short or open

POWERTEC Model 1000AR Drive Start Up and Troubleshooting Chart

Page 1

NOTE: This chart assumes standard control connections and no options installed which affect speed control.
 CC = Current Controller board.
 SC = Speed Controller board.

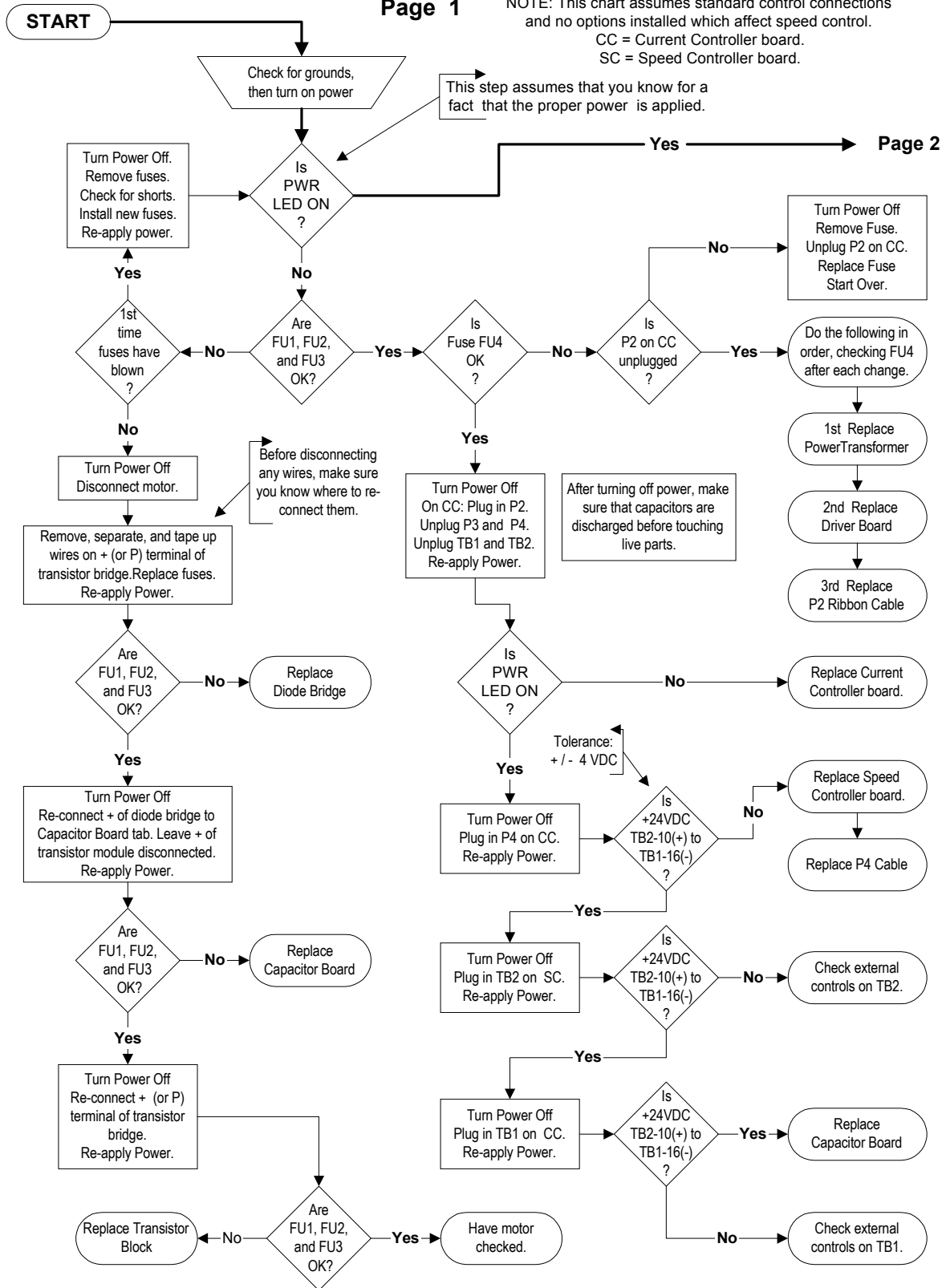

DIODE BRIDGE TEST

Equipment : A **Digital Multi-Meter (DMM)** with a diode scale is preferred. You should have a RED lead in the positive (+) input and a BLACK lead in the negative (-) input.

Preparation: Different meters give different readings on diode tests. **KNOW YOUR METER !!** Some meters read backwards due to battery polarity. Test YOUR meter on a known good diode bridge before performing tests so that you know how your meter will act.

Precautions: If the diode bridge is to be tested in circuit, make sure power has been off long enough for the capacitor banks to completely discharge.

Procedure: The procedure is the same for in circuit or out of circuit testing. If a component tests bad in circuit, it must be tested again after it is removed because of the possibility of alternate paths when the component is in circuit.

1. Set the DMM on the diode scale.
2. Place the RED (positive) lead on the “-“ or “N” terminal of the diode bridge. Place the BLACK (negative) lead on each of the AC terminals in turn. In each case you should read about 0.300 to 0.700 on a digital meter. If you see a short or an open circuit, disconnect the wires from the diode bridge terminals and re-test.
3. Repeat the above step with the BLACK lead on the “+” or “P” terminal of the diode bridge, placing the RED lead on each of the AC terminals.
4. Place the RED lead on the “+” or “P” terminal and the BLACK lead on the “-“ or “N” terminal. It should read an open circuit.

TRANSISTOR LEAKAGE TEST

Equipment: A **Digital Multi-Meter (DMM)** is preferred. You should have a RED lead in the positive (+) input and a BLACK lead in the negative (-) input.

Preparation: Set the meter on the 1000VDC scale. Be sure the leads are insulated for this voltage. Refer to page 28 for the drive power schematic and semi-conductor diagrams.

Precautions: **This test is an in-circuit test with power on.** It should be performed by personnel who have been trained to work around high voltage.

Procedure: Turn the drive power off and disconnect motor leads T1, T2, and T3. Turn the power on and wait for the bus to charge (a green BUS LED). If the bus will not charge, turn power off and go to TRANSISTOR MODULE STATIC TEST. Measure the BUS voltage (POSITIVE BUS to NEGATIVE BUS) before beginning.

1. Place the Red lead of the meter on the POSITIVE BUS. Place the BLACK lead, in turn, on T1, then T2, then T3. In each case, notice the voltage reading.
 - If any voltage reading is 0 VDC, there may be a bad transistor. Turn off power, disconnect the transistor module connected to the T lead with the bad reading, and perform the TRANSISTOR MODULE STATIC TEST.
 - If any voltage reading is the same as the BUS VOLTAGE, it may indicate a problem in the opposing transistor in that T lead leg or an unexpected alternate path in the circuit.
2. Repeat the above test with the BLACK lead on the NEGATIVE BUS and touching the RED lead, in turn, to T1, T2, and T3. Check the transistor block connected to any T lead reading 0 VDC or BUS voltage.
 - If any voltage reading is 0 VDC, there may be a bad transistor. Turn off power, disconnect the transistor module connected to the T lead with the bad reading, and perform the TRANSISTOR MODULE STATIC TEST.
 - If any voltage reading is the same as the BUS VOLTAGE, it may indicate a problem in the opposing transistor in that T lead leg or an unexpected alternate path in the circuit.

POWERTEC Model 1000AR Drive Start Up and Troubleshooting Chart

Page 2

NOTE: This chart assumes standard control connections and no options installed which affect speed control.
CC = Current Controller board.

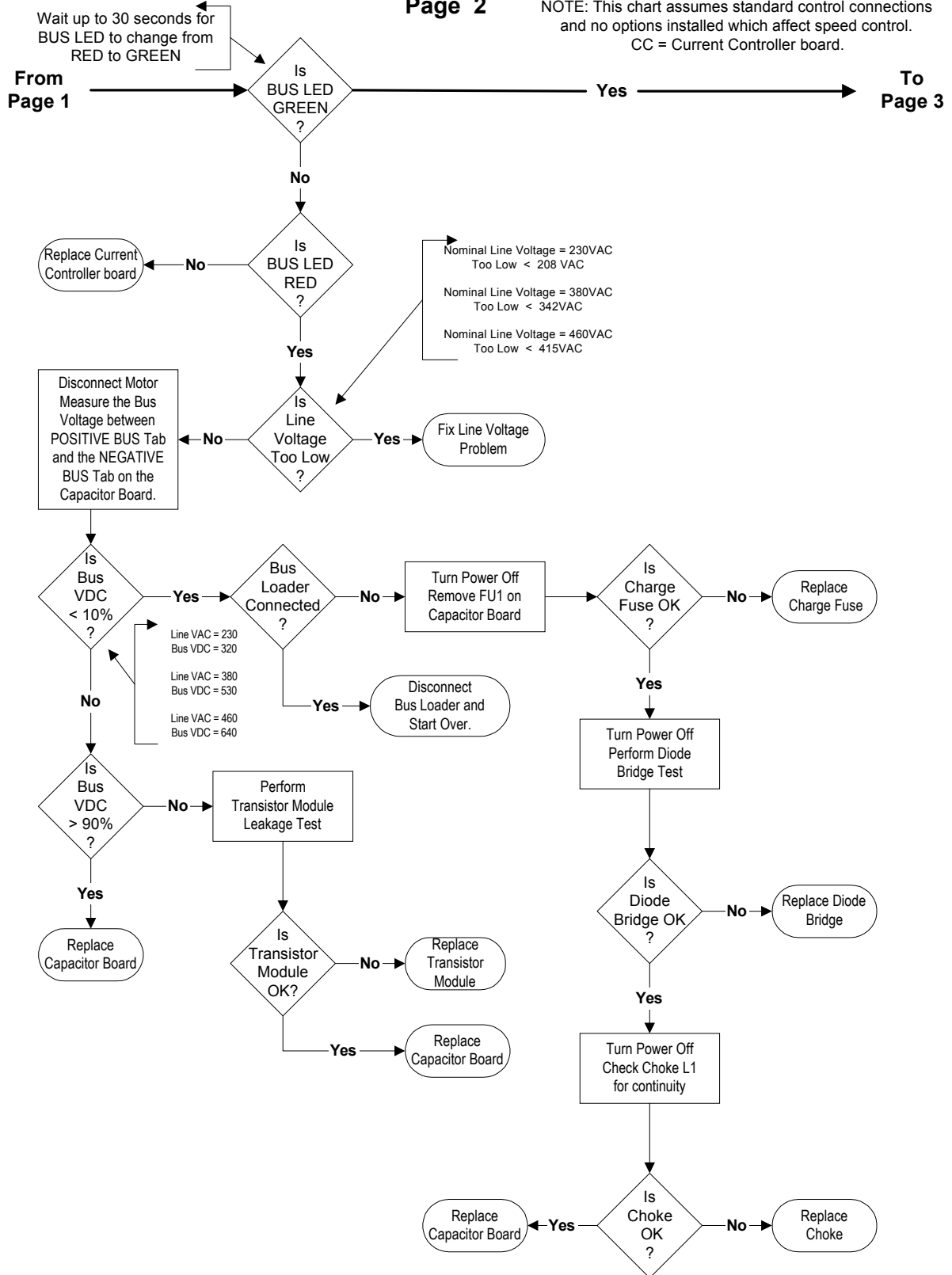

ENCODER WAVEFORMS

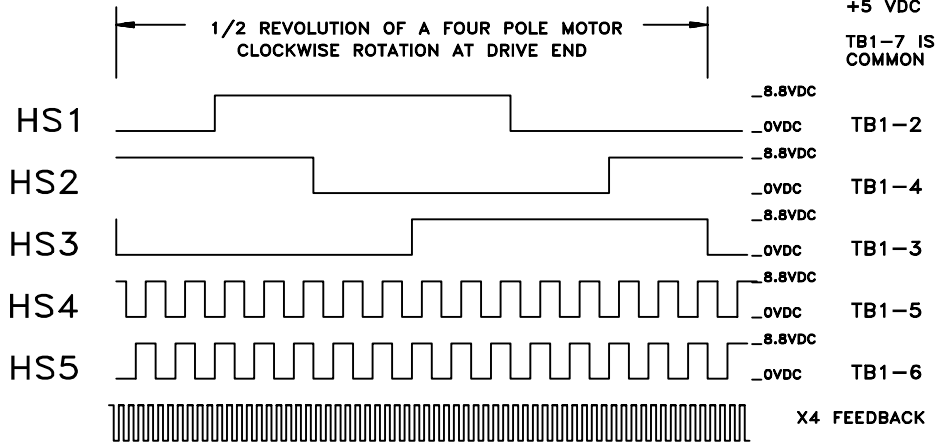

MOTOR ENCODER CONNECTIONS IN MOTOR TERMINAL BOX

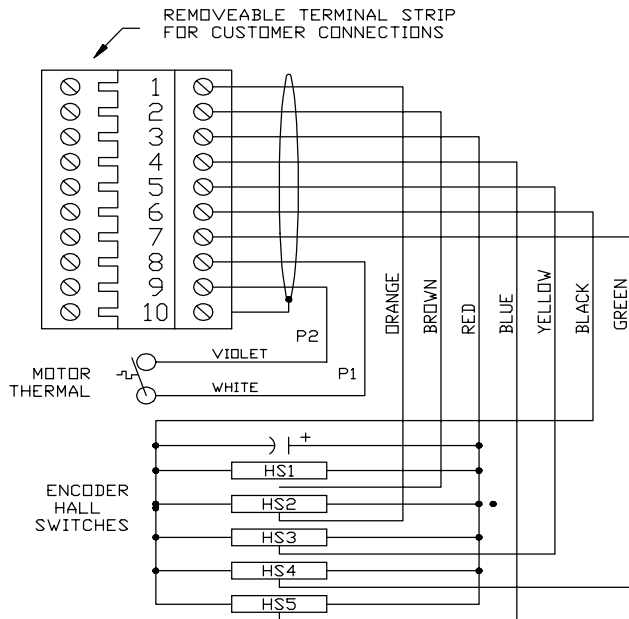

MOTOR ENCODER LAYOUT

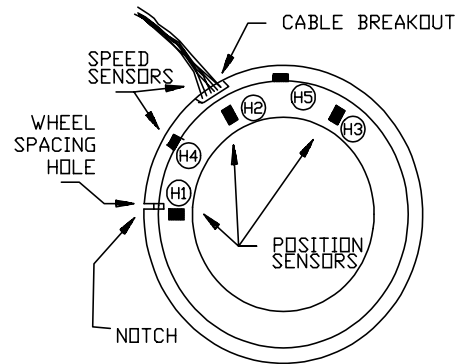

IOC TESTS:

An Instantaneous Over Current (IOC) fault is a serious matter. An IOC fault is indicated when the drive has detected a potentially damaging amount of current going into the output transistor stage. Whenever possible, avoid trying to restart the drive after an IOC fault until the following tests have been performed:

1. Turn off power and wait for the main power capacitors to discharge.
2. Turn the ILIMIT potentiometer fully Counter-ClockWise (CCW).
3. Disconnect the motor power leads and check the motor for grounds.
4. With power still off, perform the Transistor Module Static Test (page 32).
5. Re-apply power and perform the Transistor Leakage Test (page 34).
6. If any of the Driver board LED's are on now, change the driver board.
7. Press the START button and rotate the motor slowly by hand. Watch the driver board LED's to see which ones are turning on and off. If the IOC LED comes on at some point in the rotation, change the transistor block connected to that driver.
8. Turn off the power and, after the main capacitors have discharged, re-connect the motor and test the entire motor power circuit for grounds again.
9. Turn power on and begin the start-up procedure again, turning up the ILIMIT potentiometer slowly to catch a possible overcurrent event.

OV/UV TESTS:

An OverVoltage/UnderVoltage (OV/UV) indication may come on for many reasons. The important point to remember is that the OV/UV indicator applies to the BUS voltage.

Make sure there are no common buss connections or bus loaders causing problems with the proper charging and maintenance of the bus voltage.

1. Before turning off the main power, measure the AC line voltage at the input to the drive. It should be the nameplate voltage +/- 10%. If it is not, correct it.
2. Assess when the OV/UV indication occurred. The OV/UV trip occurs:
 - If the BUS voltage exceeds 121% of nominal bus (see troubleshooting chart, page 35 for voltages) for any period of time. This may occur if the line voltage exceeds 121% of nominal, or
 - If the BUS voltage drops to less than 85% of nominal bus voltage for a period of time exceeding 80 milliseconds (0.08 seconds), or
 - If the BUS voltage drops below 75% of nominal bus voltage for any length of time, or
 - If the charging contactor drops out.
3. In the case of 380VAC and 460VAC drives, check the balance of the voltage across the capacitor bank halves. (Measure across R1 and R2). The voltages should not differ by more than 10%. If the voltages are unbalanced, change the Capacitor board.
4. Do not assume that the AC line voltage which is measured while the drive is off will be the same while the drive is running the motor under load. Measure the AC line voltage under both circumstances.

POWERTEC Model 1000AR Drive Start Up and Troubleshooting Chart

Page 4

NOTE: This chart assumes standard control connections and no options installed which affect speed control.
CC = Current Controller board.

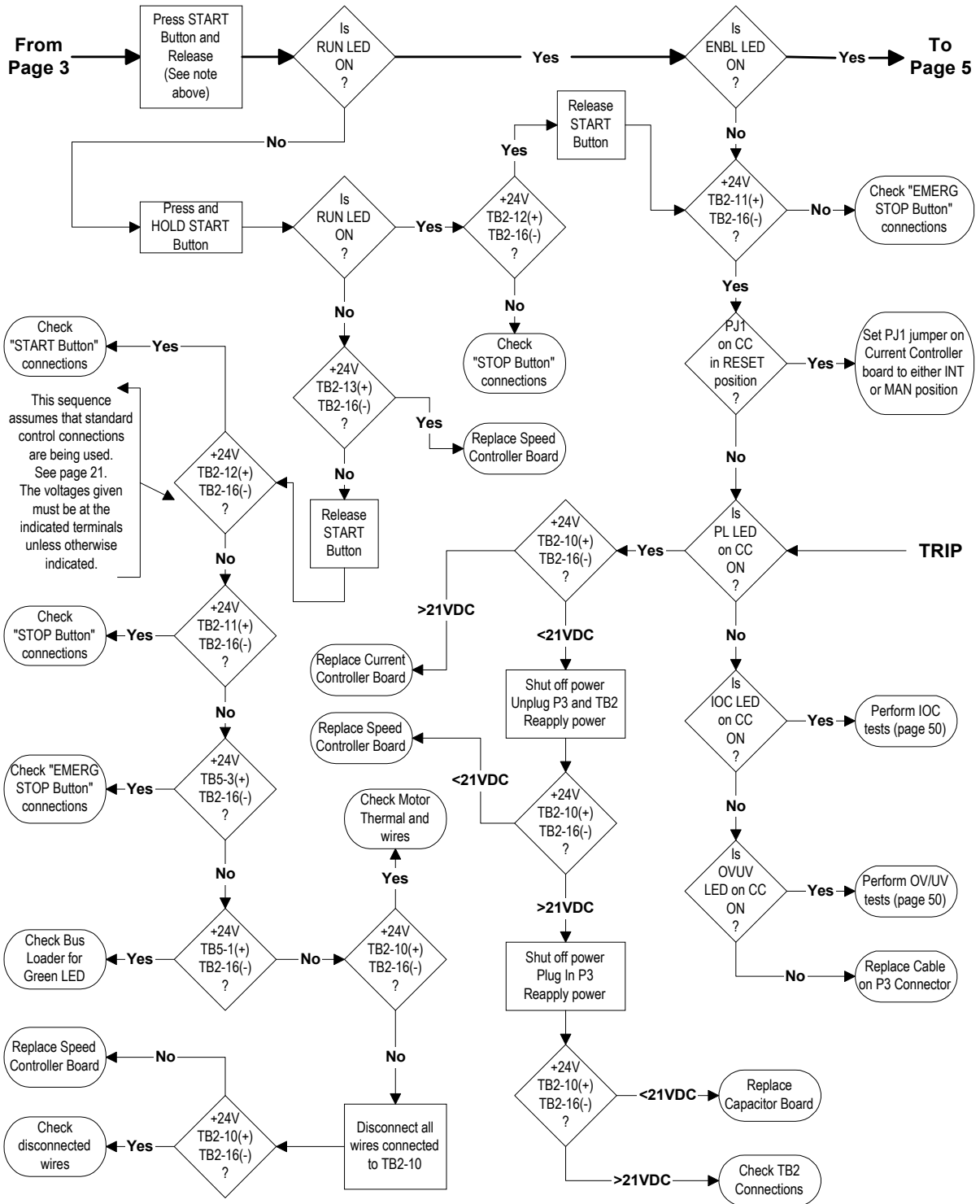

POWERTEC Model 1000AR Drive Start Up and Troubleshooting Chart

Page 5

NOTE: This chart assumes standard control connections and no options installed which affect speed control.
CC = Current Controller board.

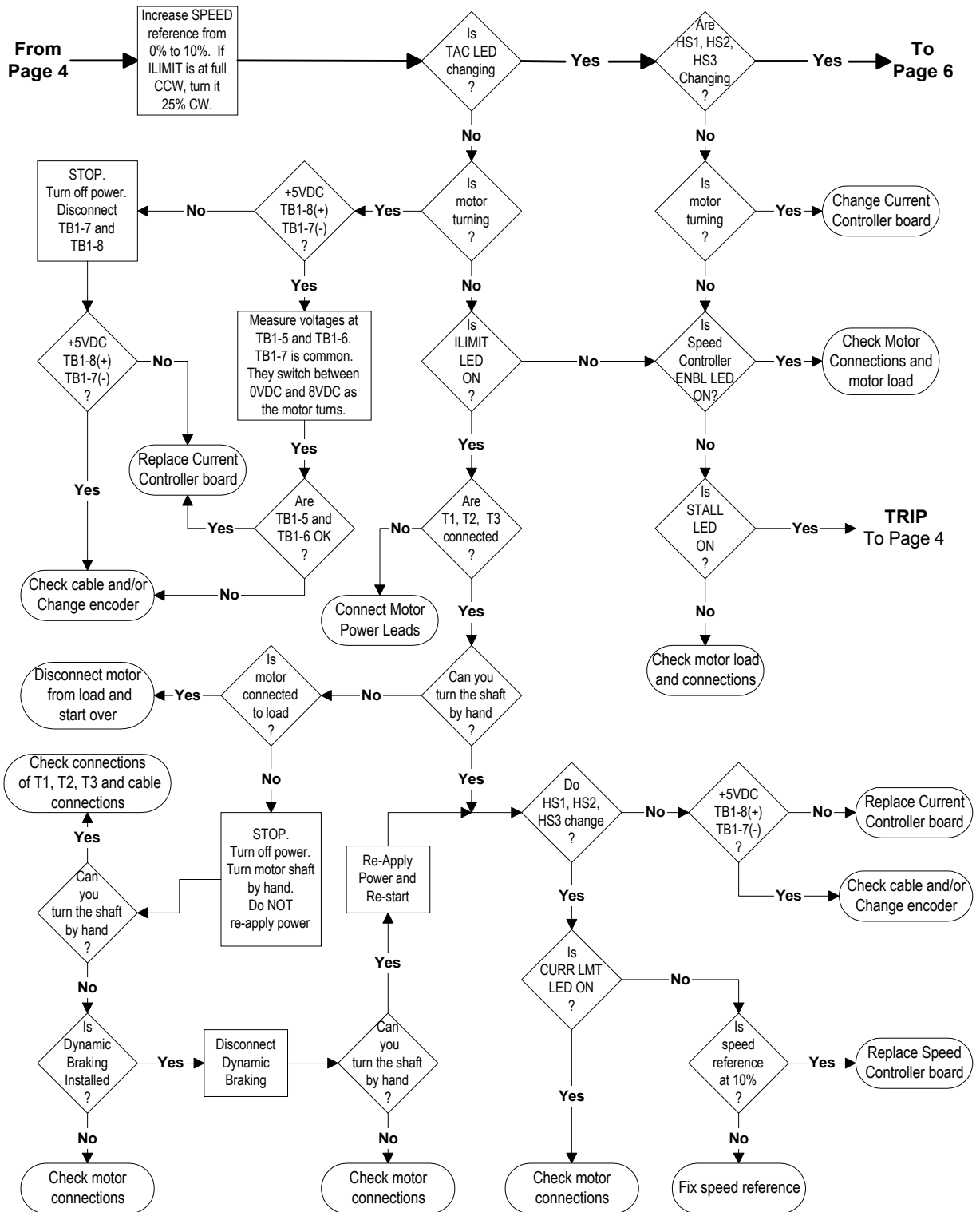

DRIVER BOARD LAYOUT AND CONNECTIONS

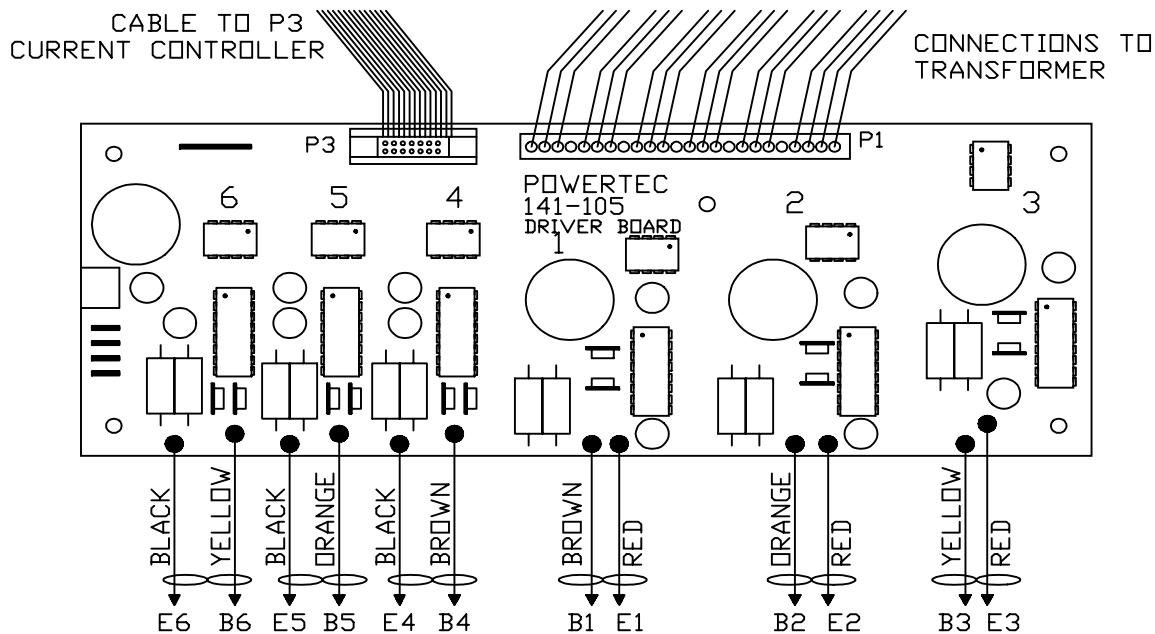

DRIVER BOARD LED'S

The base driver board LED's turn on when current is being supplied to the bases of the output power transistors.

For output transistor numbering, see the Simplified Power Schematic drawing on page 32.

On the Model 1000 series non-regenerative drives, transistors #1, #2, and #3 (referred to as the "top" transistors because they are connected to the positive side of the bus) are "block fired", i.e., they are on continuously while the motor is in a position where they should be on. On a four-pole motor (standard motors with frame sizes from 42T through 259T), each of the output transistors 1, 2, and 3 are on for 60 degrees of shaft rotation. This makes the LED's for transistors 1, 2, and 3 easy to see while the motor is running.

Transistors #4, #5, and #6 are each enabled for 60 degrees of shaft rotation while the motor is in the corresponding position, but the output transistor is controlled by a "pulse-width modulation" (PWM) which is determined by the motor current required. Under light loads, this means that the transistor may only be on 1 percent of the time. The LED's for #4, #5, and #6 (referred to as the "bottom" transistors because they are connected to the negative side of the bus) therefore, may be difficult to see. As the load increases on the motor, observation becomes easier.

The best way to check the LED's on the Base Driver Board is to disconnect the motor power leads T1, T2, and T3, start the drive, and rotate the motor shaft by hand. Then all of the LED's will come on at full brightness.

POWERTEC Model 1000AR Drive Start Up and Troubleshooting Chart

Page 6

NOTE: This chart assumes standard control connections and no options installed which affect speed control. CC = Current Controller board.

